

Flite-Veyor®

INCLINE FLAT BOTTOM DRAG CONVEYORS

MODELS 1017 - 1417 - 1817 - 2017 - 2417

INSTALLATION & OPERATING INSTRUCTION MANUAL

Manufactured in the U.S.A. by



P.O. Box 1086, 2000 E. Leffel Lane • Springfield, Ohio 45501
Toll Free: 1-800-334-7254 (in U.S.A. & Canada) • Phone: 937-325-1511 • Fax: 937-322-1963

www.sweetmfg.com

STANDARD CONDITIONS - TERMS OF SALE

Orders are subject to the approval of Sweet Manufacturing Company in writing at Springfield, Ohio, U.S.A., or by shipment of goods. All orders are considered firm contracts. Shipping dates are only our estimate based upon time required for production, and we shall not be liable for any claims for delays beyond our control, nor shall we accept cancellations or suspensions unless agreed upon, at the same time protecting us against loss caused by such cancellation or suspension.

The title and right to possession of the goods covered by order shall remain with Sweet Manufacturing Company until complete and final payment therefore shall have been paid to Sweet Manufacturing Company in cash, including any interest or other auxiliary charges provided for. All goods covered by order will be considered as personal property until completely paid for, regardless of mechanical attachment to real estate.

No material shall be returned without our authorization. Where written consent of Sweet Manufacturing Company is given for the return of unused goods, the purchaser will pay a minimum handling charge of fifteen percent (15%) of the original purchase price of the goods returned.

WARRANTY - All items manufactured by Sweet Manufacturing Company are warranted against defects in material or workmanship for one (1) year from the date of shipment (but not against damage caused by accident, abuse, or faulty installation). Sweet Manufacturing Company will replace free of charge (F.O.B. point of supply), all such defective parts if returned to the factory, charges prepaid. All items manufactured by others and resold by Sweet Manufacturing Company are warranted to the full extent of the warranties furnished by such original manufacturer. No allowances will be made for repairs, alterations or changes unless specifically authorized by us. There are no other warranties, expressed or implied, other than title, freedom from liens, and against patent infringement. SELLER MAKES NO WARRANTY OF MERCHANTABILITY OR FITNESS FOR A PARTICULAR PURPOSE.

LIMITATION OF LIABILITY - Liability of Sweet Manufacturing Company to the purchaser for damages arising out of the manufacture, sale, delivery, use or resale of the equipment, whether based on warranty, contracts, negligence, or otherwise, shall be limited to and shall not exceed the cost of the repair or replacement of defective part or parts. Upon expiration of the warranty, all such liabilities shall terminate. Sweet Manufacturing Company shall not be liable to the purchaser or user for loss of anticipated profits, loss by reason of plant shutdown, non-operation, increased expenses of operation of other equipment, or other consequential loss or damage of any nature arising from any cause whatsoever by reason of the manufacture, sale, delivery, use, or resale of the equipment covered by this order or contract.

A minimum charge of Fifty Dollars (\$50.00) net, exclusive of transportation charges, will be made on all orders, unless otherwise noted on invoice for the value of such material as less than this amount.

All prices are F.O.B. Springfield, Ohio, U.S.A., unless otherwise agreed. Additional charges may be made for special handling, extra packing, or unusual services. Open account terms will be extended subject to approval of our Credit Department. Any federal or state taxes, sales, use, or other taxes will be added to invoice when and if assessed. All prices are subject to change without notice.

Sweet Manufacturing Company

P. O Box 1086
2000 E. Leffel Lane
Springfield, OH 45501

Toll Free: 800-334-7254
(U.S.A. & Canada)
Phone: 937-325-1511
Fax: 937-322-1963
E-mail: sales@sweetmfg.com

Flite-Veyor[®]

INCLINE

TABLE OF CONTENTS

INTRODUCTION	1
CHECK & INSPECT YOUR ORDER	1
INCLINE FLITE-VEYOR[®] FUNCTION	1
TYPICAL INSTALLATIONS	2
SELECTING THE PROPER CONVEYOR	3
MODEL IDENTIFICATION & CAPACITY	4
GENERAL	5
INSTALLATION & ASSEMBLY OF INCLINE FLITE-VEYORS[®]	5
OPTIONAL INTERMEDIATE DISCHARGE INSTALLATION	6
INLET ASSEMBLIES	6
INLET INSTALLATION	7
DUMP HOPPER	9
INSTALLATION OF CHAIN	9
PREVENTING PERMANENT CHAIN TWIST	11
DRIVE ASSEMBLY	11
ELECTRICAL EQUIPMENT	14
MAINTENANCE	14
SAFETY	15
TROUBLESHOOTING	16

Purchase Date _____ Model _____

Serial Number _____

INTRODUCTION

The purpose of this Owner's Manual is to advise and instruct owners of the Flite-Veyor® Incline Flat Bottom Drag Conveyors (hereafter referred to as Incline Flite-Veyor®) and accessories in the recommended installation, operation, and maintenance of the equipment.

The instructions and drawings provide a step-by-step method of installation procedures. Even though installation procedures may vary because of different applications, it is suggested that if there are any questions, you refer to the instructions in this manual. To ensure long life and trouble-free operation it is recommended that you perform regular maintenance as discussed in this manual.

IT IS THE INSTALLER'S RESPONSIBILITY TO BE AWARE OF ALL FEDERAL, STATE AND LOCAL SAFETY AND ELECTRICAL CODES DURING THE INSTALLATION AND USE OF THE INCLINE FLITE-VEYOR®.

CHECK & INSPECT YOUR ORDER

Each order or shipment is double checked before leaving the factory. All parts, pieces and components are listed item by item on our packing list, which accompanies each order. The number and description of each item, package, container, skid, etc. is listed on the bill of lading. **IN SIGNING THE BILL OF LADING, THE CARRIER ASSUMES FULL RESPONSIBILITY FOR SAFE DELIVERY OF ALL GOODS TO DESTINATION IN THE SAME ORDER AS CARRIER WAS TENDERED BY THE SHIPPER.** In the event of damage or shortage, have the transportation company note the same on the freight bill. You should then file a claim against the carrier for such loss and/or damage.

You will find a packing list attached to one of the items in the shipment. Check each item against the list. Check by description, specification, quantity, count, etc. Should there be any discrepancies, notify us immediately. If an order or shipment includes more than one Incline Flite-Veyor®, the parts for each conveyor will be keyed or marked on the packing list for easy identification.

Small parts and items such as bolts, washers, bushings and keys are just as important to an installation as the other components. Make sure these are located and checked before disposing of any containers or packing. We cannot be responsible for loss of items that are listed and included on our packing list.

Should there be some delay between the time an order is received and the ensuing installation, store parts in a protected area so they may be easily located and identified. **RETAIN PACKING LISTS FOR THIS REASON, AS WELL AS FOR FUTURE PARTS REFERENCE.**

INCLINE FLITE-VEYOR® FUNCTION

The Incline Flite-Veyor® function is different from that of the Sweet® Horizontal Flite-Veyor®. They are both drag style chain conveyors; however, the Horizontal Flite-Veyor® is an en masse style conveyor that utilizes the biggest portion of the trough height to carry material. The Incline Flite-Veyor® is not classified as an en masse type conveyor. The incline conveyor utilizes about one half of the trough height to carry the material and uses a center pan to help hold the material on the carrying side and assist the chain on the return side.

Care must be taken when designing a system to utilize an Incline Flite-Veyor®.

TYPICAL INSTALLATIONS

The typical uses of the Incline Flite-Veyor® are shown in Figure A.

The Incline Flite-Veyor® is typically used to feed a bucket elevator when an elevator boot pit is not desired. The conveyor can be used as a straight incline or can utilize curved sections with either a 15°, 30° or 45° curve. There are other uses for the Incline Flite-Veyor®, including but not limited to the following:

Conveying materials across the top of bins

Where an installation may require different bin heights and it is desired to use a single conveyor, a 'straight' Incline Flite-Veyor® will work. Using the optional intermediate discharge gates, different bins can be loaded. If intermediate discharge gates are used, it is recommended to allow the head to discharge as well. This will allow any carry-over material to discharge the conveyor to prevent buildup which can cause the conveyor to plug.

Unloading of bins

Multiple use of openings in the bin floor rather than a single center drop-out will reduce the amount of material left in the bin as it is emptied. **CAUTION!** Always unload bin from the center drop-out first to prevent structural failure of the bin.

With drive-over pit

Material is unloaded into the hopper mounted directly on the Incline Flite-Veyor®. Sweet manufactures bypass dump hoppers for use in these applications.

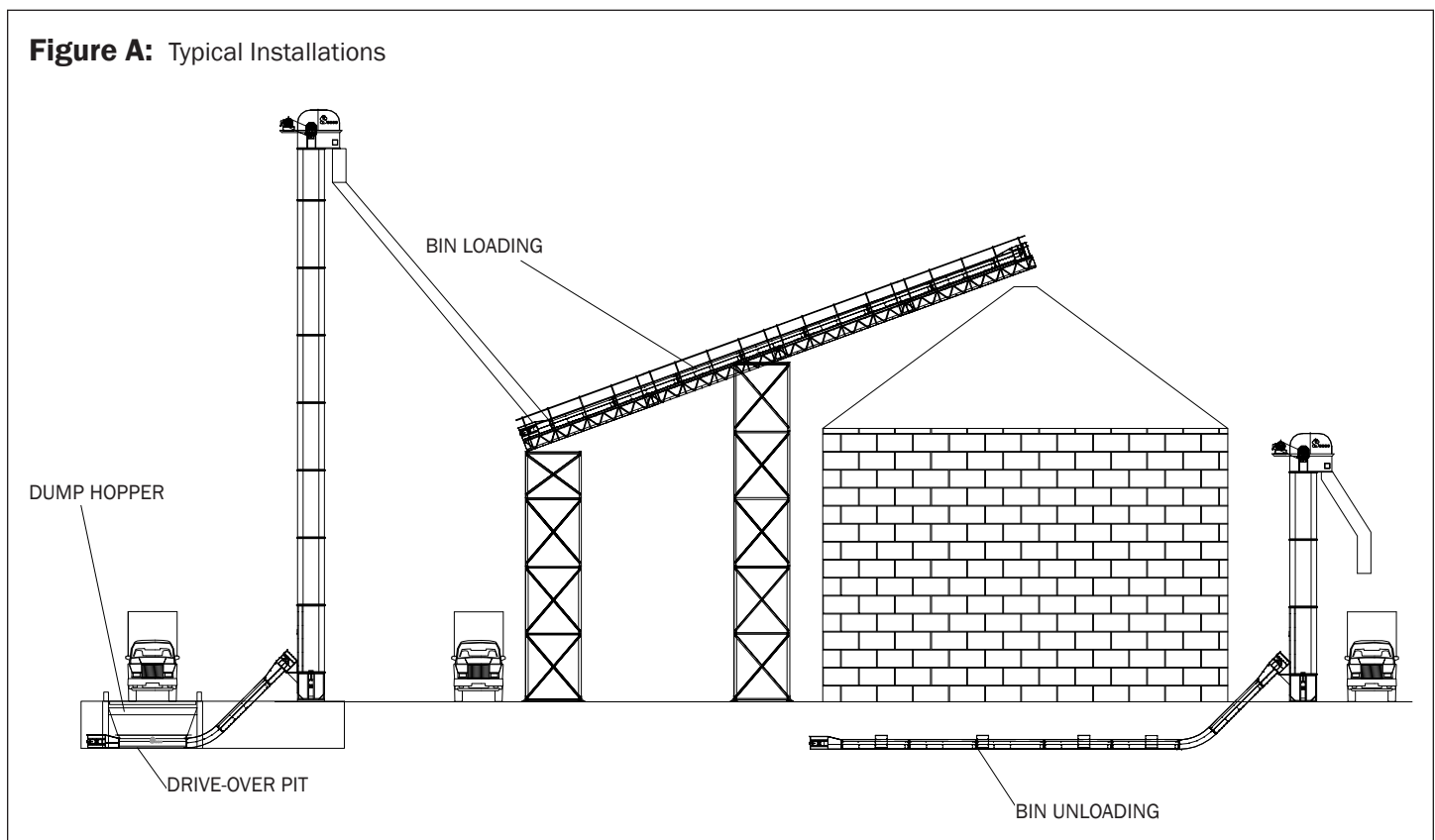

SELECTING THE PROPER CONVEYOR

Consideration must be given to the following items before ordering an Incline Flite-Veyor®:

- Desired capacity of the conveyor: It is smart system design to use a conveyor that has slightly less capacity than the equipment into which it is discharging, if applicable. This will prevent plugging of the conveyor and make for better system design.
- The type of product conveyed: Every product has its own flow characteristics, so it is likely that capacity results will vary by product. This is especially important to consider when using the same conveyor to handle multiple products.
- The number and type of inlets required: When using an Incline Flite-Veyor®, it is preferred to use the bypass inlets or bypass dump hoppers. Extra standard style inlets are available. However, they require that an opening be cut in the center pan, and this can affect the overall performance of the conveyor.
- The slope of the conveyor, if using a straight incline.
- The curve required with the horizontal and incline length.
- The number and type of intermediate discharges desired.

The Incline Flite-Veyor® can be used to feed the boot of a bucket elevator using one of the optional discharge transitions or using one that is fabricated in the field by a millwright (See Figure B).

Figure B

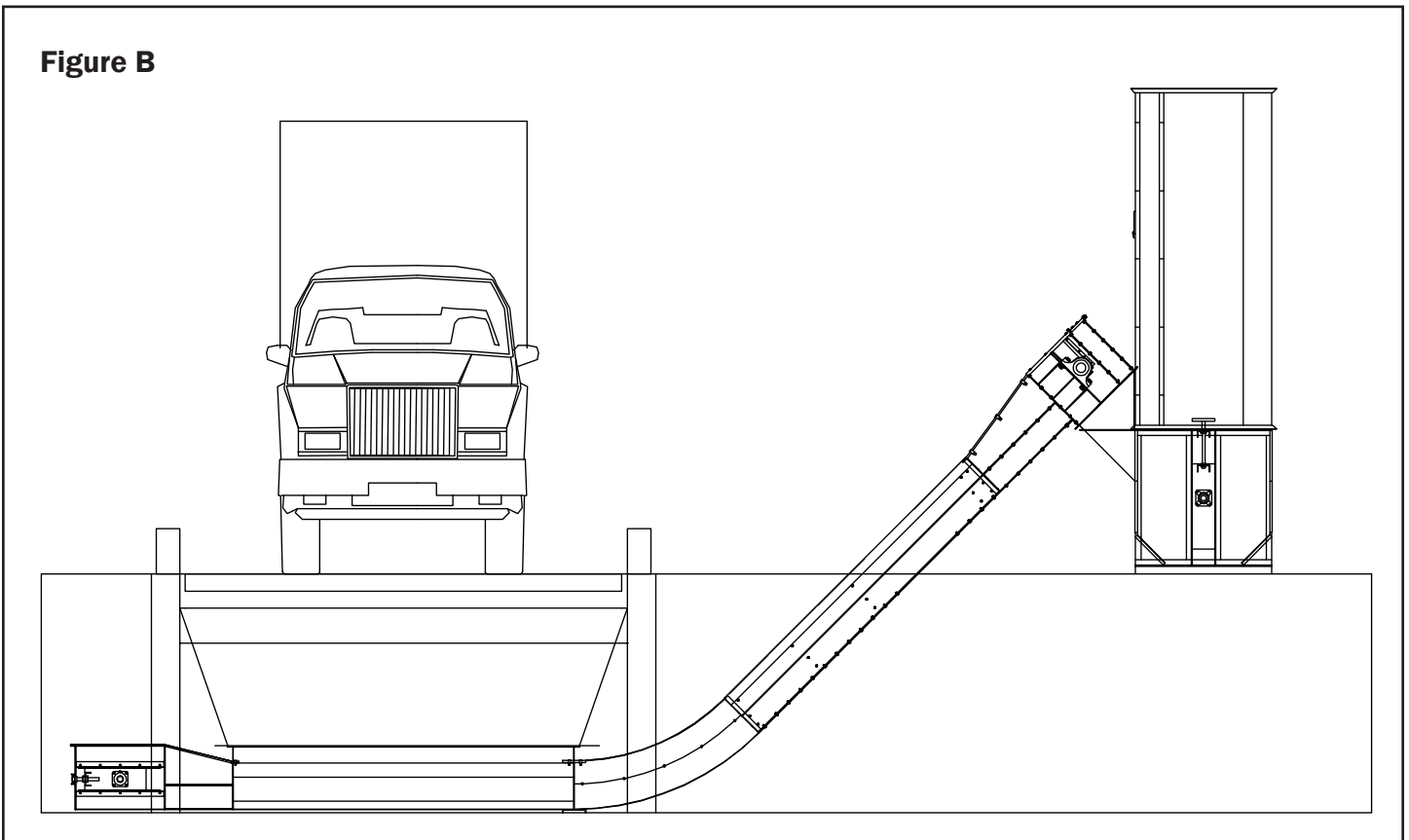

MODEL IDENTIFICATION & CAPACITY

Use Figure C to identify the model of Incline Flite-Veyor® required, as well as capacities and dimensions.

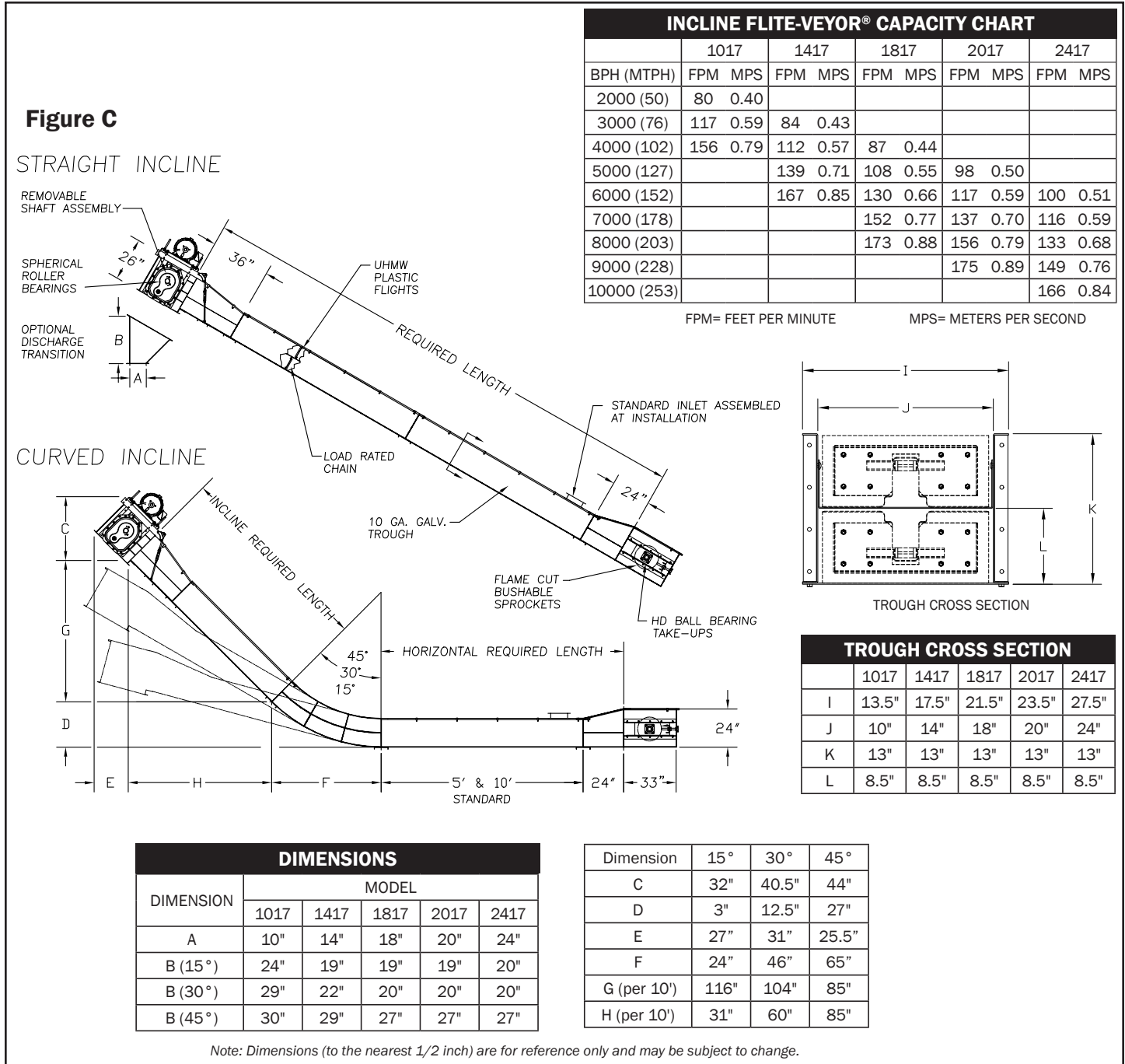

GAUGES & SPECIFICATIONS

HEAD WITH 3' TRANSITION	3/16 ga.	Sides with pillow block, self aligning double row spherical roller bearings
TAIL WITH 2' TRANSITION	10 ga.	Sides with flange block ball bearings and take-up
TROUGH	10 ga.	Sides and Bottoms
COVERS	14 ga.	Bolted flat covers
CHAIN		D88K, D88C, D308C

ABRASION RESISTANT LINERS: Available for trough sides and bottoms. Gauge options include 10 ga., 3/16" and 1/4" and will be quoted upon request.

GENERAL

Only proper installation can offer the performance intended by the manufacturer. Therefore, a good installation should be of prime concern to the customer and to the installer responsible for the same. **A MANUFACTURER CANNOT BE RESPONSIBLE FOR THE INSTALLATION OF A CONVEYOR.** The suggestions and information contained herein are offered solely as a convenience, for we assume no liability as to installation, either expressed or implied.

Unless the location of the equipment has been predetermined by a layout drawing or print, careful consideration should be given as to the depth of pits, location of inlets, possible obstructions, etc. Plan ahead for the location of supports and bracing.

When the Incline Flite-Veyor® is used to feed a bucket elevator or another conveyor, provision must be made for proper clearances to allow for drives, discharges, valves, etc. on all equipment. Also, enough clearance should be provided to allow proper maintenance of equipment after it has been installed. Proper planning prior to installation can eliminate flow plan problems.

Supporting the conveyor on a catwalk requires bolting the unit down to the catwalk every 10 feet, as shown in Figure D. These attachment brackets are available from Sweet Manufacturing Company.

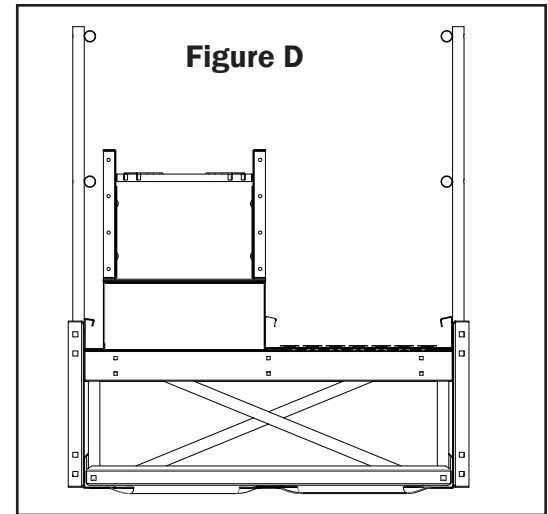

INSTALLATION & ASSEMBLY OF INCLINE FLITE-VEYORS®

The desired length and height of the conveyor is achieved through a combination of head, tail, and trough sections. Lay out the unit as it will be used, including the head and tail sections which arrive fully assembled from the factory. The head assembly comes with the splice channel installed. Incline Flite-Veyor® troughs are available in up to 10' sections. The trough is assembled by bolting adjacent end flanges together using 3/8" x 3/4" bolts and nuts. The bottom is joined using a bottom splice channel. The head and tail connect to the trough with splice channels, as well. To attach the bottom splice channel, remove the end bolts in the bottom of two adjacent trough assemblies and match the splice channel to holes in the two trough sections. Do not lift trough lengths greater than 40' with a maximum of 20' between lift points. The conveyor should be supported every 10', or one place per conveyor section when installed. These channels come with pre-punched holes to allow mounting in various situations. To attach the bottom splice channel, remove the end bolts in the bottom of two adjacent trough assemblies and match the splice channel to the holes in the two trough sections (See Figure E).

The trough sections are assembled in the factory. However, care must be taken when bolting the troughs together to ensure the center pans and bottoms are aligned properly. The center pan has oversized holes to allow for adjustment. **NOTE: Be sure to align return pan and bottom liner for smooth transition of chain and paddles of conveyor from trough section to trough section.**

WARNING: If mismatches occur in either location, it will create a catch point for the flights and cause premature wear of the flights, a decrease in conveyor performance and excessive noise.

Apply silicone caulk to the flanges prior to assembly of the trough sections. Loosely install the connecting hardware. It is recommended that a taught line be used to ensure that conveyor sections are straight horizontally. As stated earlier, exercise care to ensure that the inside trough bottom and the center pans are aligned. Adjust as necessary. Shims may be used as required to achieve proper horizontal and vertical alignment. Once the conveyor is aligned, tighten connecting hardware.

Recheck all hardware for proper tightness, including bearing bolts, bearing set screws, tapered bushings, etc. These are tightened when they leave the factory; however, during shipment some hardware may have loosened.

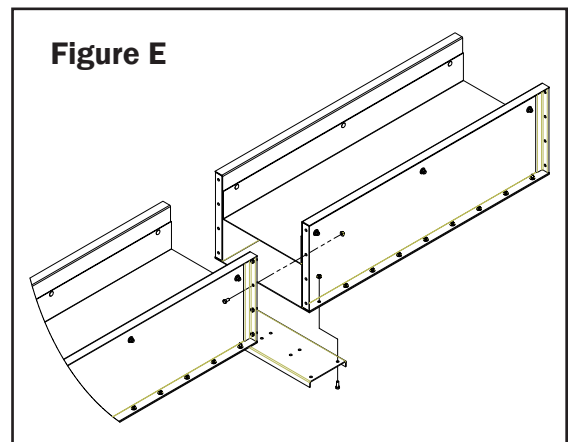

OPTIONAL INTERMEDIATE DISCHARGE INSTALLATION

Even though the use of an intermediate discharge is not likely in the installation of an Incline Flite-Veyor®, the following procedure should be used:

- 1) Determine the location of the center of the intermediate discharge from the tail or head section. Typical intermediate discharge gates are shown in Figure F.
- 2) Locate the discharge flight support plate in the center of the discharge and make a mark at each end of the support plate onto the trough bottom. The standard bottom can then be removed from the trough assembly and cut so the discharge flight support can be installed where the piece was removed. If the existing holes in the trough sides cannot be used, new ones must be drilled to fit the discharge flight support plate and the top flange of the intermediate discharge. The internal cut edge of the trough bottom should be ground smooth to prevent interference with the chain flighting as it passes over the opening.
- 3) Bolt the intermediate discharge and the discharge flight support plate to the trough. The rack and pinion side may extend either to the left or the right side of the conveyor.

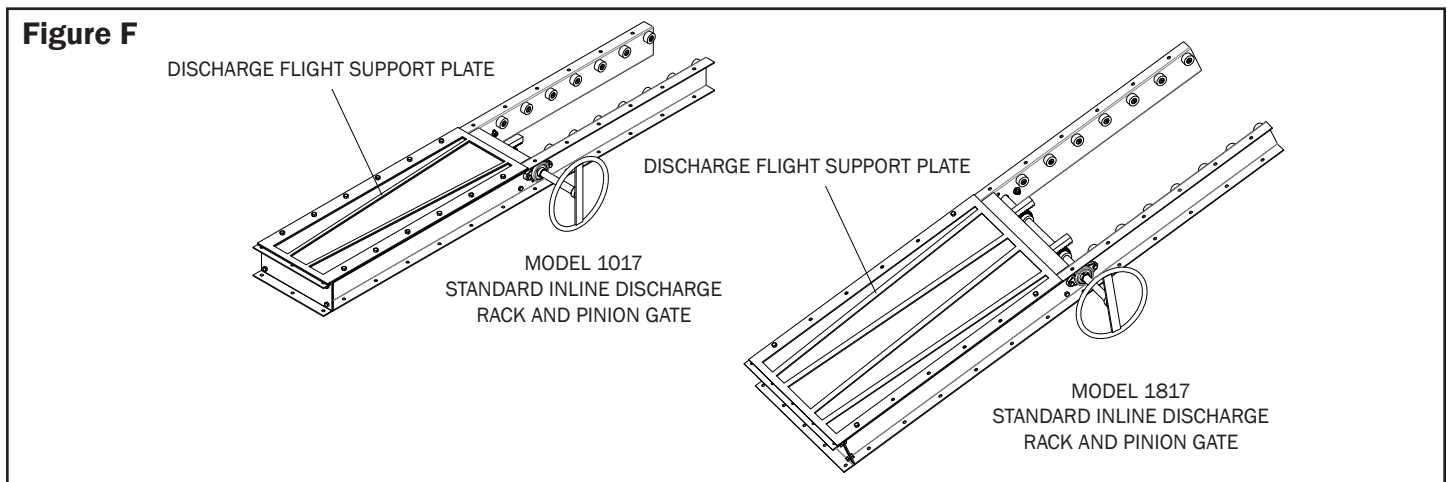

INLET ASSEMBLIES

BYPASS INLET HOPPER

The bypass inlet hopper is 18" long, 22" tall and 12" wider than the basic conveyor trough. It provides a regular flow of material onto the chain and paddles. Bypass inlet hoppers are field installed, as shown in Figure I.

BYPASS DUMP HOPPER

The bypass dump hopper provides a regulated flow of material onto the chain paddles. This reduces material damage, chain shock and horsepower requirements.

STANDARD SQUARE FRAME INLET

The standard (square frame) inlet is mounted directly on top of the conveyor trough. This should only be used where some other means of controlling the flow is above the inlet (e.g., rack and pinion valve). **Standard inlets are not recommended as intermediate inlets on an Incline Flite-Veyor®.** Use bypass inlets instead. The standard inlet mounting requires that the middle pan be cut out, as shown in Figure K, when being installed on an Incline Flite-Veyor®.

INLET INSTALLATION

The preferred inlet for the Incline Flite-Veyor® is either a bypass inlet (See Figure G) or a bypass dump hopper (See Figure H). Both are available from Sweet Manufacturing. The bypass inlet fits over the trough and requires cutting the trough in a few places to allow for the material to flow around the return side of the chain and feed in the carrying side of the chain. It may be best to install these before the chain is completely installed to prevent damaging the UHMW flights of the chain (See Figure G). The bypass dump hopper, also known as a pit hopper, as shown in Figure H, actually replaces a piece of trough and no additional modifications to the conveyor are necessary.

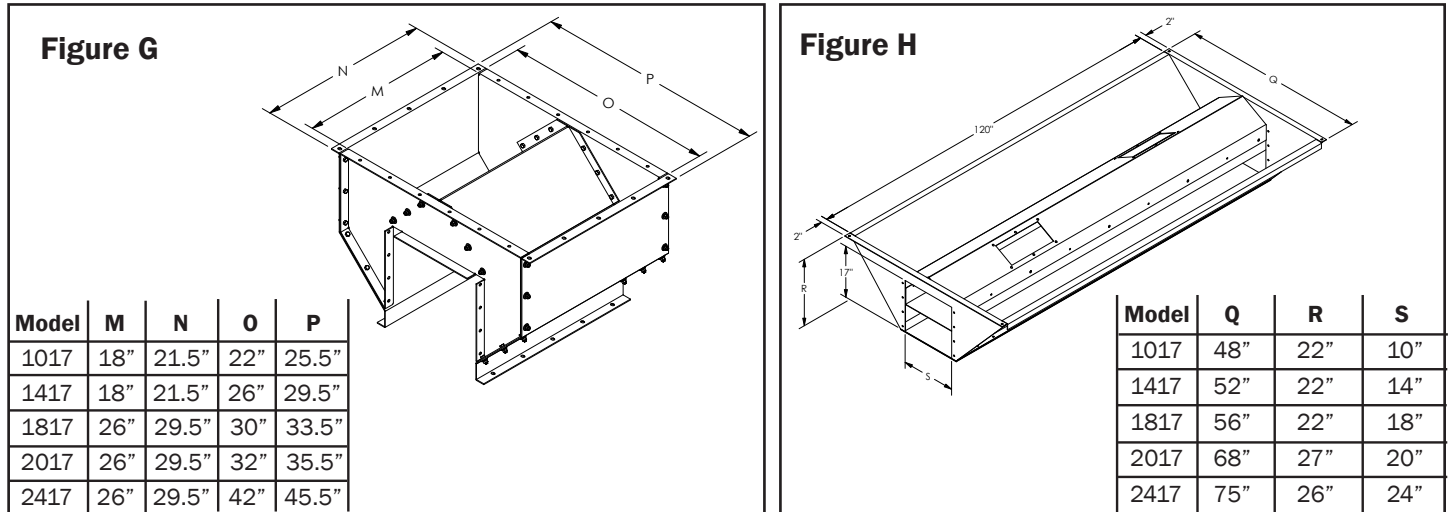

Note: Dimensions (to the nearest 1/2 inch) are for reference only and may be subject to change.

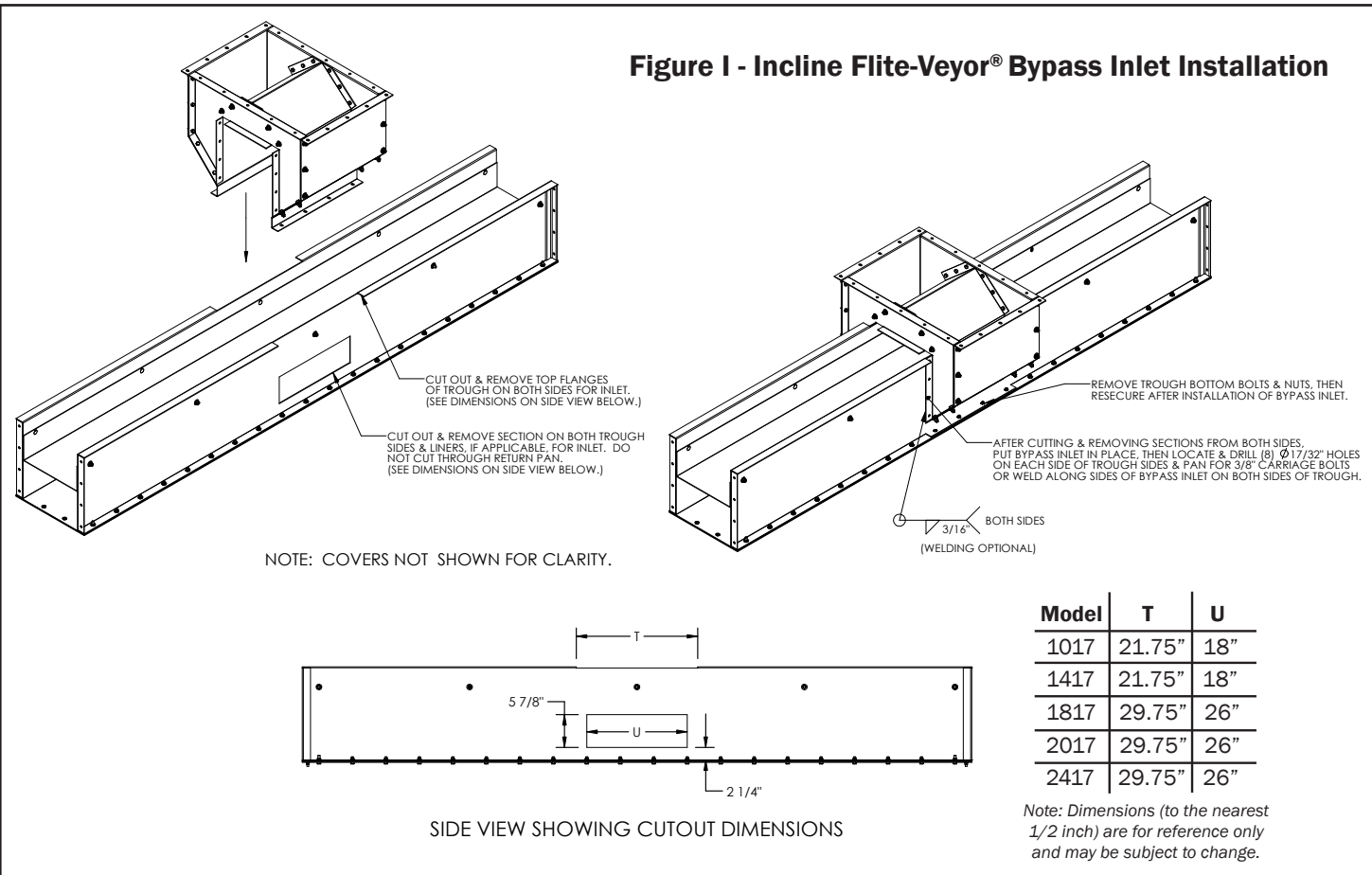

INLET INSTALLATION (CONTINUED)

Sweet Manufacturing also makes the standard rectangular inlet that mounts to the top of the conveyor (See Figure J). If this inlet is used, the center pan must be modified as in Figure K. If the standard inlet is used, it must be placed on the trough sections, not on the tail transitions.

Field installed inlets should be located at least 19 1/2" from the center of the inlet to the tail section, as shown in Figure J. However, it can be moved toward the head section as needed. Additional inlets may be added at any point in the conveyor trough. Also, see Bypass Inlet Hopper in the Inlet Assemblies section.

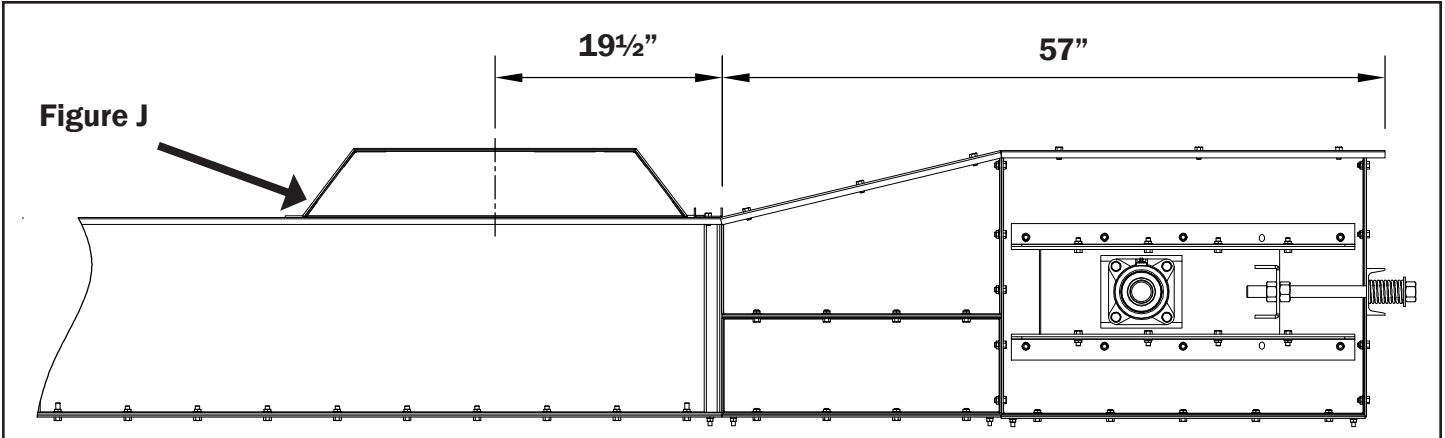

Model	A	B
1017	10"	6"
1417	14"	10"
1817	18"	14"
2017	20"	16"
2417	24"	20"

Figure K - Standard Inlet

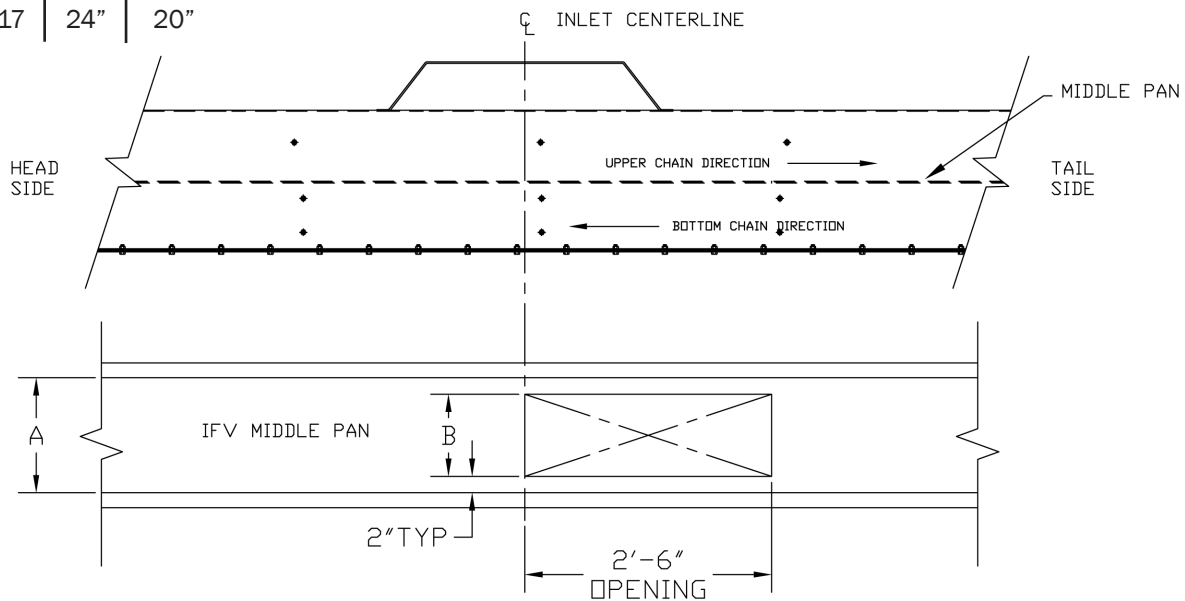

Note: Dimensions (to the nearest 1/2 inch) are for reference only and may be subject to change.

DUMP HOPPER

A dump hopper has been developed for use with the Incline Flite-Veyor[®], as shown in Figure L, and has a 20 bushel (25 cu. ft.) holding capacity. The grain enters through openings in both sides of the trough and eliminates the drag caused by the top chain moving in the material, greatly reducing the horsepower required for pit applications. A 120" hopper pit opening unit is fabricated in standard 10' trough sections. To determine the additional horsepower required to drive the Incline Flite-Veyor[®] with a dump hopper, add 20' to the length of the conveyor. For additional information, consult Sweet Manufacturing Company's Sales Department.

Figure L

Model	Q	R	S
1017	48"	22"	10"
1417	52"	22"	14"
1817	56"	22"	18"
2017	68"	27"	20"
2417	75"	26"	24"

Note: Dimensions (to the nearest 1/2 inch) are for reference only and may be subject to change.

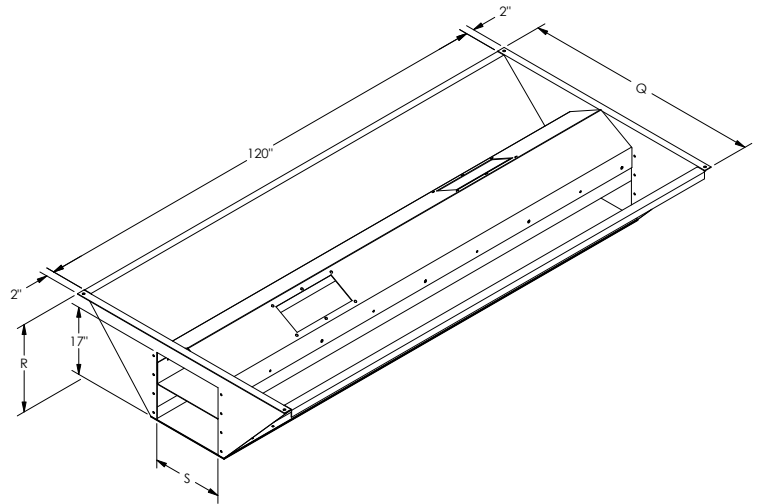

INSTALLATION OF CHAIN

Proper installation of the chain assemblies is critical for long life and performance of the Incline Flite-Veyor[®]. Use the following procedure for setting the chain tension:

Remove the covers from the trough, tail, head, transitions and curves to allow for ease of installation of the chain. Adjust the take-up on the tail so that it is in the minimum position. Begin placing the chain in the conveyor with the UHMW flights facing the direction of travel. For example, on the carrying side of the conveyor, the UHMW flights face the head; on the return side, they face the tail (See Figure M).

Figure M

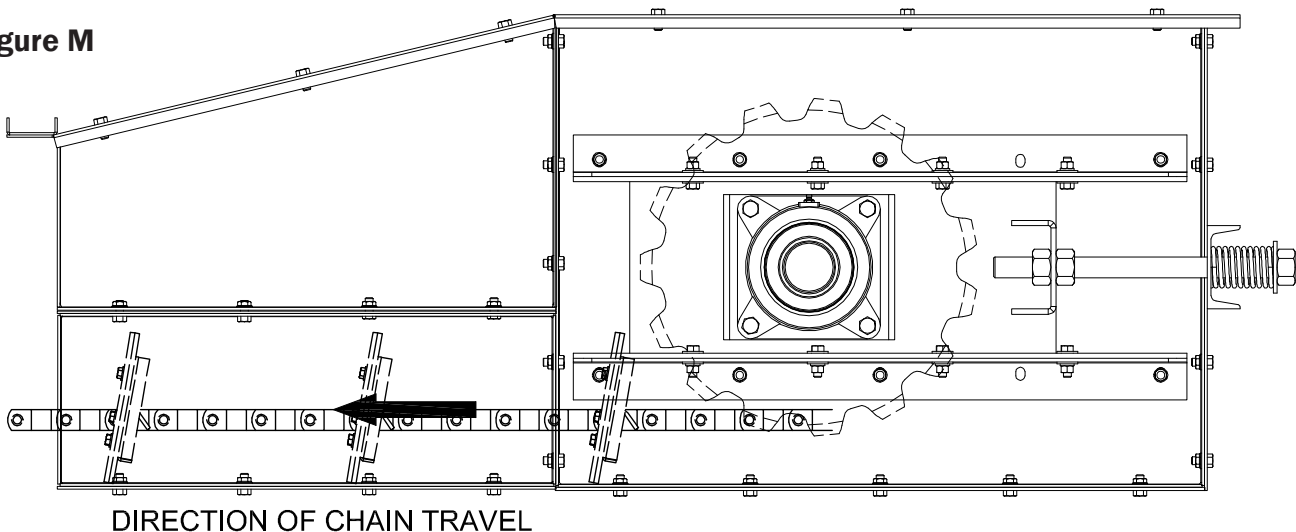

INSTALLATION OF CHAIN (CONTINUED)

On Incline Flite-Veyors® without the curve, adjust the tension of the chain so that the top of the flight on the return side, which will be the part closest to the pan, begins to touch the pan at approximately 5' away from the sprocket, or just past the transition sections on the head and tail. At this point, check the flights on the bottom or carrying side, and make sure the flights are standing upright. Most chain assemblies have a 10 degree incline to the flights, so they will never be standing fully upright. Adjust the tension as necessary. Using caution because of the moving chain and flights, manually turn the head sprocket in the direction of travel so that the chain makes one complete pass through the conveyor. The chain should be tight enough to prevent wrapping the sprocket or the flights lying down, but loose enough to move smoothly through the transitions. After making any necessary adjustments, reinstall the covers, cover splices and sealants and tighten all hardware. After reinstalling all covers, run the conveyor empty and verify that the chain has proper tension.

On Incline Flite-Veyors® with a curved trough section, adjust the chain tension so that the flights are beginning to stand straight. At this point, the top of the flights should just be touching the pan on the return side in the curve. Using caution because of the moving chain and flights, manually turn the head sprocket in the direction of travel so that the chain makes one complete pass through the conveyor. The chain should be tight enough to keep the flights erect and prevent the chain from wrapping the sprocket. The chain should also be loose enough to allow the chain to go through the curves and transitions. If the chain is hitting the cover of the curve sections, it is too tight. After making any necessary adjustments, reinstall all covers, cover splices and sealants and tighten all hardware. After reinstalling all covers, run the conveyor empty and verify that the chain has proper tension.

It is normal that a conveyor with a curve, like the Incline Flite-Veyor®, will create a noise level that is above average when compared to a straight conveyor. However, **the most common cause of the excessive noise and wear in an incline conveyor is due to the chain tension being too tight.** This is particularly true for conveyors with curved sections. The noises are from the flights hitting the covers, joints on the covers, and return pans. Also, there may be a scraping noise from curved section when the chain is too tight. The chain tension on the Incline Flite-Veyor® should never be so tight that it collapses the springs on the take-up rods or pushes up the conveyor covers. The conveyor should be more quiet when grain is being conveyed. If the conveyor becomes noisier with grain, check the tension of the chain and make sure that none of the flights are damaged. Adjust and replace as required (See Figure N).

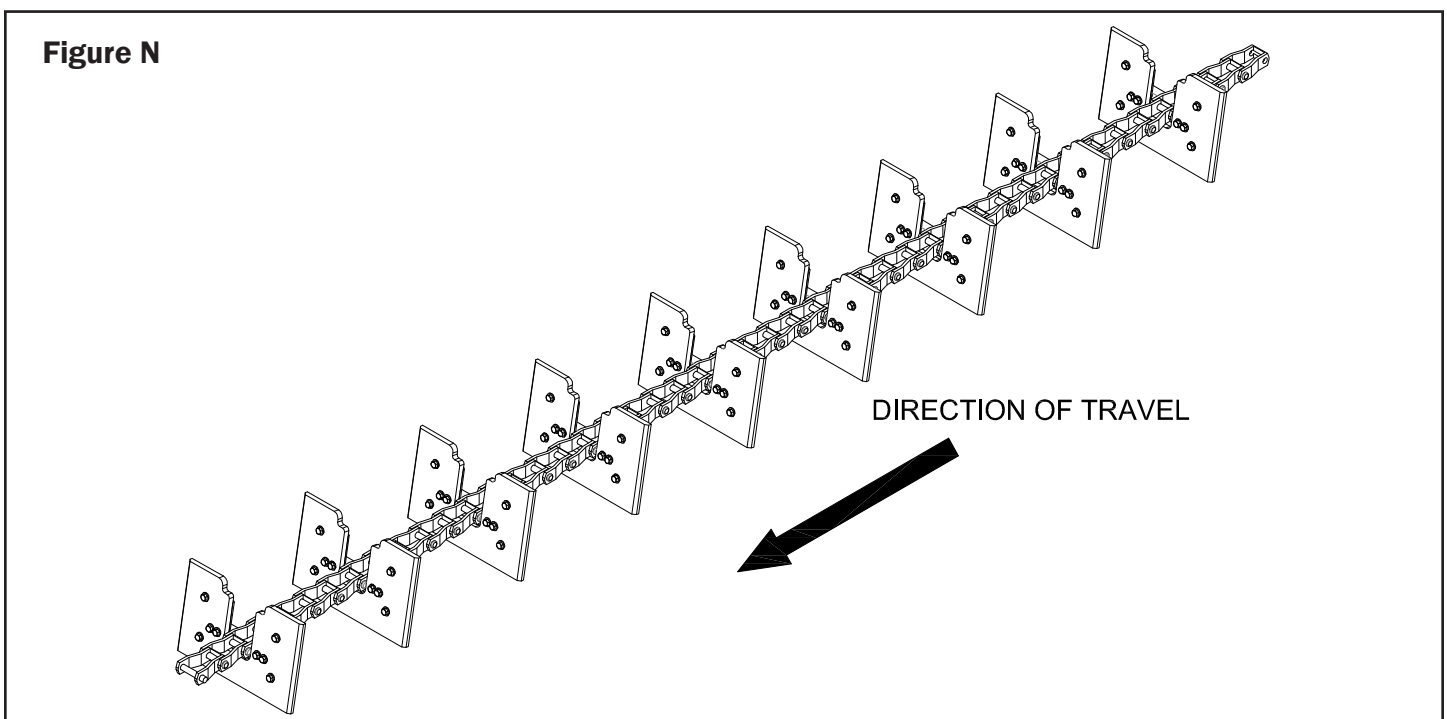

DANGER

Exposed conveyor and moving parts will cause severe injury or death. De-energize the conveyor and follow proper lockout/tagout procedures before removing the cover or inspection door. Make sure to add oil to gear reducer before operating, as it is shipped without oil. Follow the instructions with the reducer, making sure not to overfill.

PREVENTING PERMANENT CHAIN TWIST

Chain can become twisted if improperly handled. **DO NOT** turn over a length of chain by twisting one end, as shown in Figure O. This may cause a permanent twist to the chain.

Figure O

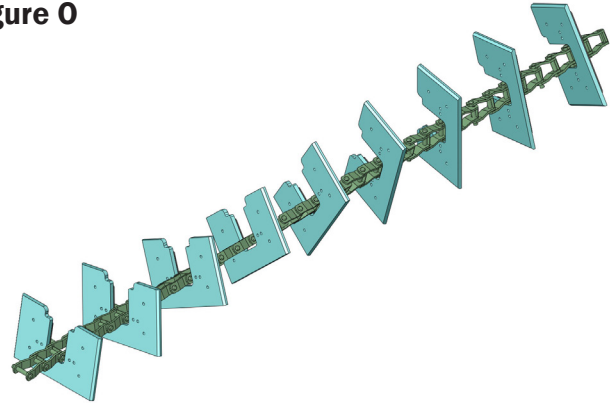

DRIVE ASSEMBLY

The typical drive assembly includes a shaft mounted gear reducer, a torque arm, reducer bushings, motor mount, sheaves and sheave bushings, V-belts and drive guards. The torque arm channel on the Incline Flite-Veyor® connects to the conveyor on the head transition section, as shown in Figure P. The standard mounting side for the drives on drag conveyors is the lefthand side of the conveyor, when looking at the head from the tail. Drives can be supplied that mount on the right side. Please specify at time of ordering. It is important to note that the gear reducers are shipped without oil. After proper placement of the reducer, make sure the oil level is at the manufacturer's recommended level before running the conveyor.

Proper installation of the shaft mounted gear reducer is essential to efficient and economical operation. Install the reducer in the following manner:

- 1) The drive shaft on the conveyor must be clean and free from burrs. Remove any protective coatings on the shaft using a nonflammable solvent.
- 2) Locate and inspect the key for the drive shaft.
- 3) Refer to your packing list for motor mount height and position of the reducer. This would be specified as M3-B, for example. The 'M3' is the motor mount height setting for the Dodge TA series reducers and 'B' is the orientation of the reducer. Refer to the Dodge TA Assembly manual for information on how to install the motor mount to the gear reducer. If the motor mount is not installed in the proper position, the drive components will not fit as specified. If the belts are too short, the height setting is possibly too high. If the motor mount hits the top of the conveyor head, or if the belts are too long, the height setting may be too short.

WARNING: Using a motor mount position different than identified could result in the V-belts being the incorrect length.

DRIVE ASSEMBLY (CONTINUED)

- 4) Once the motor mount and tapered bushings are placed on the reducer, it is ready to install on the shaft. Pick up the reducer/motor mount assembly and slide them onto the shaft. **CAUTION:** For safe handling of the reducer, use only proper lifting equipment with enough rated capacity to lift the drive assembly. Lifting the reducers by hand may be dangerous and is not the preferred way to install the reducer assembly. Do not slide the reducer all the way to the bearing, as the force may damage the bearing, and the bushing must be far enough from the bearing to allow installation and removal of the bushings.
- 5) Once the drive assembly is placed on the shaft in the proper position and the key is in the proper location in the key seat, tighten the bolts on the tapered bushings per the manufacturer's specifications. Refer to the drive manufacturer's assembly manual as required.

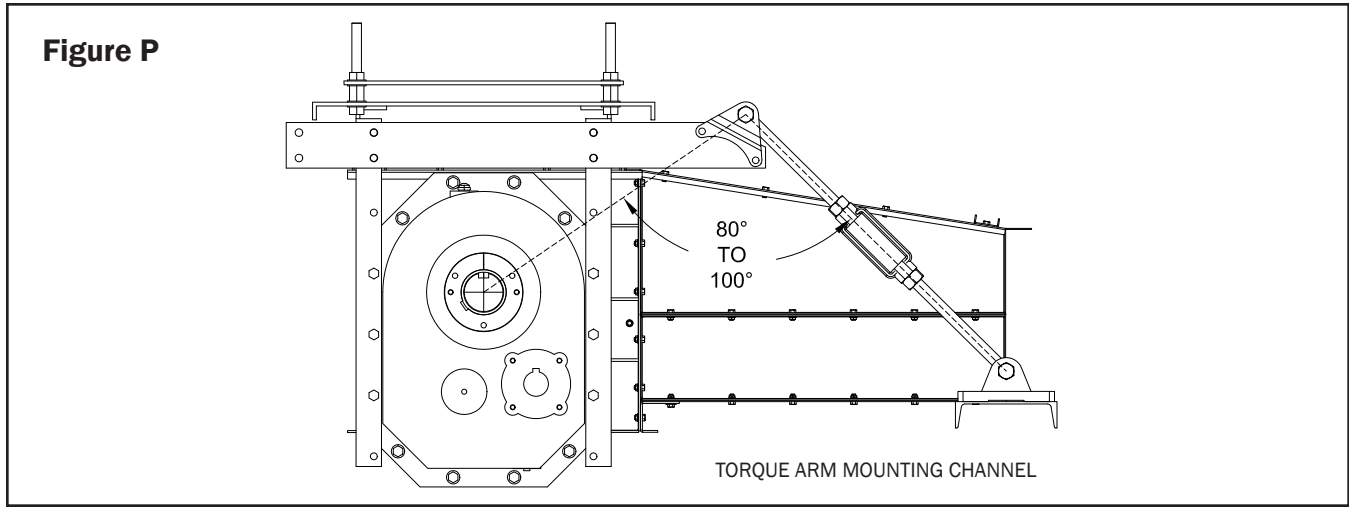

- 6) Install the torque arm on the torque arm channel and install in the proper location on the head transition section, as shown in Figure P.
- 7) Drive cover brackets (both motor and reducer sides) and the drive cover backing plate must be installed before the installation of the sheaves and V-belts. Refer to drawing number IDCK61530/66 (See Page 13) for proper installation of drive cover components.
- 8) After the drive cover backing plate is installed, mount the sheaves, bushings and V-belts. When installing sheaves, make sure they are in the proper locations. The larger sheave typically goes on the gear reducer. Mount the bushings as close to the reducer and motor as possible, making sure they are in line and proper clearance is given behind the sheaves for the bolts that fasten the drive cover brackets. Use a straight edge to verify sheaves are in line for proceeding with V-belt installation.
- 9) Install the V-belts and tighten them using the adjustments on the motor mount. The bolts on the drive cover bracket should be loose at this point. After tightening, the V-belts should have about 3/8" deflection with 6 to 9 pounds of force applied. After the proper tension is achieved, tighten all hardware and jam nuts as applicable.
- 10) Install the drive cover using the hardware provided, as shown on drawing IDCK61530/66. (See Page 13.)
- 11) Verify that the reducer has the proper amount of lubricant before running the conveyor. Refer to the manufacturer's assembly manual for the proper oil level and viscosity.

ELECTRICAL EQUIPMENT

All electrical connections should be performed by a qualified electrician. Check local codes before installation of the conveyor. Optional components such as emergency stop switches, shutoff switches, and overflow and overload devices may be required in your municipality. Controls and switches can be provided by Sweet Manufacturing Company for use on our equipment. Consult our Sales Department for items available for your conveyor.

MAINTENANCE

After approximately ten (10) hours of use, retighten all set screws on the bearings for the head and tail shafts, as well as the bushings on the sprockets and reducer. Check the chain slack in the conveyor and the V-belt tension in the drive. This should be repeated after every fifty (50) hours of operation.

CAUTION: CORRECT LUBRICATION

DO NOT START UNIT WITHOUT FIRST FILLING REDUCER WITH OIL!

SPEED REDUCER

The shaft-mounted speed reducer is lubricated by an oil reservoir in the housing. The correct amount of oil is important to the proper operation of the reducer. Too much oil may cause leakage or overheating. Too little oil may cause overheating or damage to internal parts. The "Speed Reducer Service Instruction Manual" gives a list of recommended lubricants and oil change periods.

WARNING!!

DO NOT USE lubricants of the EP (extreme pressure) type, those containing slippery additives or heavy weight (90-140 wt.) gear lube. It is recommended that oil be drained and housing flushed after the first 150 hours of operation and that the oil be changed every 2,500 hours thereafter. Check the oil level occasionally when the unit is not operating and add as required.

CAUTION!!

Keep breather holes clear at all times to prevent pressure buildup in reducer.

WARNING!!

NEVER remove breather plug or oil level plug while the drive is in operation, or personal injury may result! Check these only when drive is not operating.

INSPECTION

An inspection schedule should be established in order to ensure that the equipment is in good operating condition at all times. Regular inspections will help to reveal little things such as loose bolts, damaged paddles, etc., before they become serious and damaging problems. Here are some of the things that should be inspected and maintained regularly:

- 1) Inspect chain and paddles for loose bolts, damaged flights and chain condition.
- 2) Check chain tension; remove necessary links if it cannot be adjusted further.
- 3) Inspect V-belts for tension and condition. V-belts should be replaced with a **MATCHED SET**.
- 4) Check speed reducers regularly for sufficient oil and signs of leakage. **KEEP BREATHERS CLEAN.**
- 5) Check bearings for sufficient lubrication and evidence of overheating.
- 6) Check all sheave and drive attaching parts for sufficient tightness.
- 7) Check all hardware and tighten as required.
- 8) Check all safety labels regularly. When they become illegible, contact Sweet Manufacturing Company's Sales Department at 800-334-7254 or sales@sweetmfg.com to reorder.

SAFETY

WARNING!

Make inspections when all operations are stopped and lockout and tagout procedures are completed. The importance of exercising **EXTREME CARE** when erecting and maintaining an Incline Flite-Veyor® cannot be overemphasized. Working at heights reached by even the smallest installations can be hazardous, unless safety precautions are taken. In any case, **BE CAREFUL - DO NOT HURRY - AND REMEMBER WHERE YOU ARE AT ALL TIMES.**

Your conveyor has been designed to comply with CEMA safety standards. These safety standards can be obtained through the American Society of Mechanical Engineers as ASME B20 (1993).

Operating and maintenance personnel should be thoroughly trained in safe operating procedures, recognition of possible hazards and maintenance of a safe area around the conveyor.

Shown at right is an example of the warning sign attached to conveyor covers. (Refer to #8 under Inspection on Page 14 for instructions to reorder safety labels.)

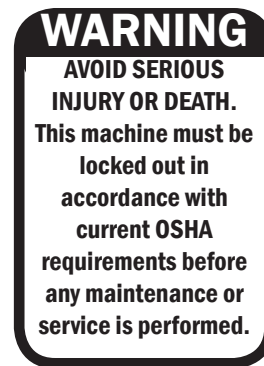

The following safety guidelines should be followed:

THESE ARE GUIDELINES ONLY AND COMPLIANCE WITH SAFETY STANDARDS - FEDERAL, STATE AND LOCAL, INCLUDING OSHA - IS THE RESPONSIBILITY OF THE USER.

- 1) Maintain a safety program for all operating personnel.
- 2) All operating personnel should be advised of the location of all emergency controls and devices.
- 3) Good lighting, housekeeping and maintenance contribute to a safe work area.
- 4) Frequent inspections should be made of all conveyor equipment, and all safety devices should be in position and in proper working order.
- 5) Conduct a pre-startup safety check of all conveyor equipment to determine that the machinery and area are safe for operation and that guards and warning devices are in place.
- 6) There should be absolutely **NO** reckless actions or horseplay in the vicinity of conveyors. Most accidents are caused by lack of proper safety training, carelessness, horseplay and lack of awareness of possible hazards.
- 7) Conveyors should not be operated unless the conveyor housing completely encloses the moving elements and power transmission guards are in place. If the conveyor cover or housing is to be opened, the motor must be locked out/tagged out electrically in such a way that it cannot be restarted by anyone in the vicinity or remotely from the conveyor. Overflow cover sections or doors should not be opened while the conveyor is operating.
- 8) If, because of its application, the conveyor must have open housing, then the entire conveyor must be separated from personnel areas by a fence, and warning signs must be posted.
- 9) Open feed hoppers or spouts for shovel, front end loaders or their manual or mechanical loading must incorporate a grating. If the characteristics of the material being handled are such that a grating cannot be used, then the exposed portion of the conveyor must be guarded by a fence and warning signs must be posted.
- 10) **DO NOT** walk or stand on the conveyor cover, grating or power transmission guards.

TROUBLESHOOTING

Problem	Cause	Remedy
Incorrect capacity	Conveyor not running full	Verify that inlet is not backed up or that the equipment feeding conveyor is not plugged.
	Incorrect chain speed	Verify that the head shaft speed is what was ordered. If within one to two RPM of what was sold this is not the problem. If the head shaft RPM is drastically different, the causes could be improper sheaves, V-belts slipping, improper gear reduction on reducer or an electrical problem. Correct situations as required.
	Improper inlet installation	If the standard inlet is used, the return pan must be cut to prevent the material from making its way to the tail. Verify that the standard inlet is installed as shown in this manual. Too much material being carried to the tail affects the overall HP requirements and efficiency of the conveyor. If using a standard bypass or pit hopper, verify that the material is feeding into the conveyor areas.
	Bent or missing flights	Replace and/or straighten as needed.
	Conveyor plugged with product	Verify that the discharge is not clogged or backing up. Conveyor may be running too fast to discharge, allowing material to return on the return side. Slow conveyor down as required to prevent plugging. Also, may need to regulate feed into conveyor.
Noisy conveyor	Flights banging on bottoms or return pans	Improper alignment of conveyor sections.
	Flights hitting trough covers	Chain too tight. Chain should not be rubbing covers over entire length of conveyor. Ideally, the chain should ride just below the covers on the trough.
	Conveyor making squeeling noise	Some noise is acceptable. The sound of the flights rubbing the pans and bottoms makes this type of noise. However, if the noise doesn't quiet down when running the conveyor with product, there may be other issues. If the noise is concentrated to the curved section, the chain may be too tight to allow the flights to move and curve. Readjust tension on chain and run conveyor again.
	Damaged flights	Replace damaged flights as required.
	Loose flights	Tighten as required.
	Chain and/or sprockets worn	Replace as required.

TROUBLESHOOTING (CONTINUED)

Problem	Cause	Remedy
Excessive UHMW flight wear	Conveyor sections misaligned	Align conveyor sections and return pans as required to realign sections.
	Sprockets not aligned and/or centered	Center sprockets and realign as necessary. Check set screws on bushings to make sure the sprockets do not move from alignment.
Sprockets showing uneven wear	Worn chain	Replace chain as required.
	Improper sprocket alignment	Center sprockets and realign as necessary. Check set screws on bushings to make sure the sprockets do not move from alignment.

CAUTION: As chain and/or sprockets wear and need replacement, the chain manufacturer recommends replacing both for longer life of the replacement parts.



Our Mission

***To provide innovative quality solutions that create
an extraordinary customer experience.***