

“RB” Flite-Veyor®

Round Bottom Models 9” - 12” - 14” - 16”

INSTALLATION & OPERATING INSTRUCTION MANUAL

Manufactured in the U.S.A. by



MANUFACTURING COMPANY

P.O. Box 1086 / 2000 E. Leffel Lane • Springfield, Ohio 45501
Toll Free: 1-800-334-7254 (in U.S.A. & Canada) • Phone: 937-325-1511 • Fax: 937-322-1963

website: www.sweetmfg.com • e-mail: sales@sweetmfg.com

STANDARD CONDITIONS - TERMS OF SALE

Orders are subject to the approval of Sweet Manufacturing Company in writing at Springfield, Ohio, U.S.A., or by shipment of goods. All orders are considered firm contracts. Shipping dates are only our estimate based upon time required for production, and we shall not be liable for any claims for delays beyond our control, nor shall we accept cancellations or suspensions unless agreed upon, at the same time protecting us against loss caused by such cancellation or suspension.

The title and right to possession of the goods covered by order shall remain with Sweet Manufacturing Company until complete and final payment therefore shall have been paid to Sweet Manufacturing in cash, including any interest or other auxiliary charges provided for. All goods covered by order will be considered as personal property until completely paid for, regardless of mechanical attachment to real estate.

No material shall be returned without our authorization. Where written consent of Sweet Manufacturing is given for the return of unused goods, the purchaser will pay a minimum handling charge of fifteen percent (15%) of the original purchase price of the goods returned.

WARRANTY - All items manufactured by Sweet Manufacturing Company are warranted against defects in material or workmanship for one (1) year from the date of shipment (but not against damage caused by accident, abuse, or faulty installation). Sweet Manufacturing will replace free of charge (F.O.B. point of supply), all such defective parts if returned to the factory, charges prepaid. All items manufactured by others and resold by Sweet Manufacturing are warranted to the full extent of the warranties furnished by such original manufacturer. No allowances will be made for repairs, alterations or changes unless specifically authorized by us. There are no other warranties, expressed or implied, other than title, freedom from liens, and against patent infringement. SELLER MAKES NO WARRANTY OF MERCHANTABILITY OR FITNESS FOR A PARTICULAR PURPOSE.

LIMITATION OF LIABILITY - Liability of Sweet Manufacturing to the purchaser for damages arising out of the manufacture, sale, delivery, use or resale of the equipment, whether based on warranty, contracts, negligence, or otherwise, shall be limited to and shall not exceed the cost of the repair or replacement of defective part or parts. Upon expiration of the warranty, all such liabilities shall terminate. Sweet Manufacturing shall not be liable to the purchaser or user for loss of anticipated profits, loss by reason of plant shutdown, non-operation, increased expenses of operation of other equipment, or other consequential loss or damage of any nature arising from any cause whatsoever by reason of the manufacture, sale, delivery, use, or resale of the equipment covered by this order, quotation or contract.

A minimum charge of Fifty Dollars (\$50.00) net, exclusive of transportation charges, will be made on all orders, unless otherwise noted on invoice for the value of such material as less than this amount.

All prices are F.O.B. Springfield, Ohio, U.S.A., unless otherwise agreed. Additional charges may be made for special handling, extra packing, or unusual services. Open account terms will be extended subject to approval of our Credit Department. Any federal or state taxes, sales, use, or other taxes will be added to invoice when and if assessed. All prices are subject to change without notice.

Sweet Manufacturing Company

P. O Box 1086
2000 E. Leffel Lane
Springfield, OH 45501

Toll Free: 800-334-7254
(U.S.A. & Canada)
Phone: 937-325-1511
Fax: 937-322-1963
E-mail: sales@sweetmfg.com

“RB” Flite-Veyor®

TABLE OF CONTENTS

INTRODUCTION	1
CHECK & INSPECT YOUR ORDER	1
TYPICAL INSTALLATIONS	2
SELECTING THE PROPER CONVEYOR	3
MODEL IDENTIFICATION	3
CAPACITY CHART	4
GENERAL	4
INSTALLATION & ASSEMBLY OF STANDARD CONVEYORS	5
OPTIONAL INTERMEDIATE DISCHARGE	5
INSTALLATION OF CHAIN	6
CHAIN HANDLING	7
INLET	7
BY-PASS INLET	8
PIT HOPPER	8
DRIVE ASSEMBLY.....	9
ELECTRICAL EQUIPMENT	10
INLET ASSEMBLIES	10
MAINTENANCE.....	11
SAFETY	12

Purchase Date _____ Model _____

Serial Number _____

INTRODUCTION

The purpose of this Owner's Manual is to advise and instruct owners of "RB" Flite-Veyor® conveyors and accessories in the recommended installation, operation and maintenance of the equipment. You have purchased a product which has been manufactured with utmost care and the finest materials, reflecting many years of engineering knowledge.

You now have the task of installing your equipment, either by yourself, under your supervision, or hiring the work done. Regardless of who does the installation, this manual is designed for you. The instructions and drawings give a step-by-step method of recommended installation procedures. Methods will vary among millwrights, but if you are not sure which is best, we suggest that you follow instructions in this manual.

The following information will aid you in the installation and operation of your new "RB" Flite-Veyor®. To ensure long life and trouble-free operation, you should read these instructions and provide regular, periodic maintenance. IT IS THE INSTALLER'S RESPONSIBILITY TO BE AWARE OF AND COMPLY WITH ALL FEDERAL, STATE AND SAFETY CODES, BUT NOT LIMITED TO SAFETY AND ELECTRICAL CODES.

CHECK & INSPECT YOUR ORDER

Each order or shipment is double checked before leaving the factory. All parts, pieces and components are listed item by item on our packing list which accompanies each order. The number and description of each item, package, container, skid, etc. is listed on the bill of lading. IN SIGNING THE BILL OF LADING, THE CARRIER ASSUMES FULL RESPONSIBILITY FOR SAFE DELIVERY OF ALL GOODS TO DESTINATION IN THE SAME ORDER A CARRIER WAS TENDERED BY THE SHIPPER. In the event of damage or shortage, have the transportation company note the same on the freight bill. You should then file a claim against the carrier for such loss and/or damage.

You will find a packing list attached to one of the items in the shipment. Check each item against the list. Check by description, specification, quantity, count, etc. Should there be any discrepancies, notify us immediately. If an order or shipment includes more than one "RB" Flite-Veyor® conveyor, the parts for each conveyor will be keyed or marked on the packing list for easy identification.

Small parts and items such as bolts, washers, bushings and keys are just as important to an installation as the larger parts. Make sure these are located and checked before disposing of any containers or packing. We cannot be responsible for loss of items that are listed and included on our packing list.

Should there be some delay between the time an order is received and ensuing installation, store parts in a protected area so they may be easily located and identified. RETAIN PACKING LISTS FOR THIS REASON, AS WELL AS FOR FUTURE PARTS REFERENCE.

TYPICAL INSTALLATIONS

The typical uses are shown in Figure A.

Conveying materials across the top of bins from a bucket elevator.

By using this method, the overall height requirement for the bucket elevator may be reduced. Separate drop-outs can be used for each of the bins. Material should be allowed to drop-out at the end to avoid accumulation causing the conveyor to plug when using intermediate dropouts (discharges).

Unloading of bins.

Multiple use of openings in the bin floor rather than a single center drop-out will reduce the amount of material left in the bin as it is emptied. **CAUTION!** Always unload bin from the center drop-out first to prevent structural failure of the bin.

With drive-over pit.

Material is unloaded into the hopper mounted directly on the "RB" Flite-Veyor®. Sweet manufactures by-pass dump hoppers for use in these applications.

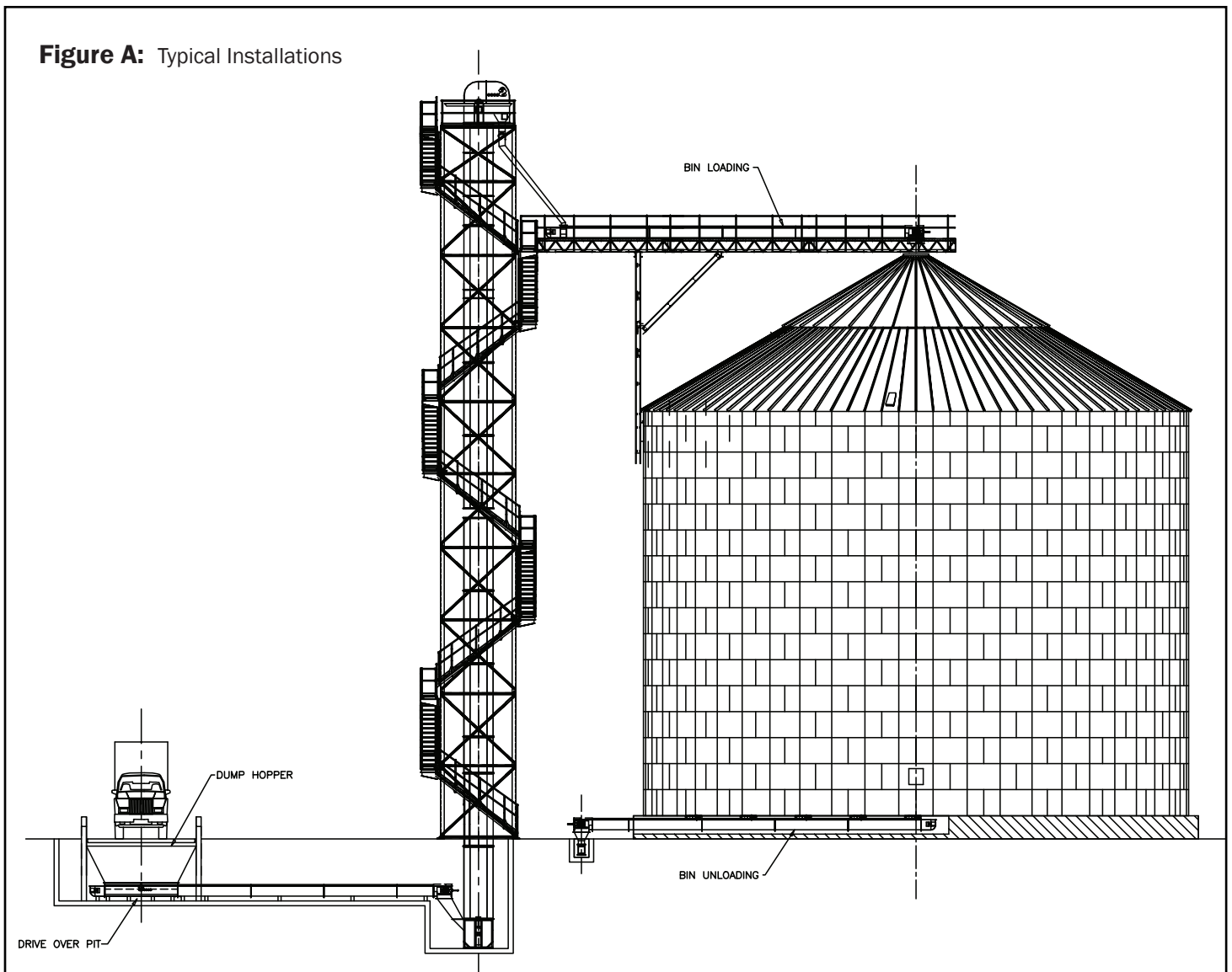

SELECTING THE PROPER CONVEYOR

The following items should be noted to properly select the conveyor: 1) type and volume of material to be conveyed, usually in bushels per hour; 2) the slope of the conveyor (slope should have been approved by Engineering for capacity required before placing order); and 3) the number and location of dropouts and type of inlets.

The "RB" Flite-Veyor® may feed the boot of a bucket elevator in these configurations:

- The head drive of the "RB" Flite-Veyor® can be placed in line with the bucket elevator, depending on the size of elevator casing and the size of the "RB" Flite-Veyor®. The "RB" Flite-Veyor® has a head take up. The take up rods on "RB" Flite-Veyor® must clear the casing.
- The "RB" Flite-Veyor® can be placed perpendicular to the elevator boot.

MODEL IDENTIFICATION & CAPACITY

Use Figures E & F to identify the model of "RB" Flite-Veyor® to select the proper procedures and dimensions in the installation process.

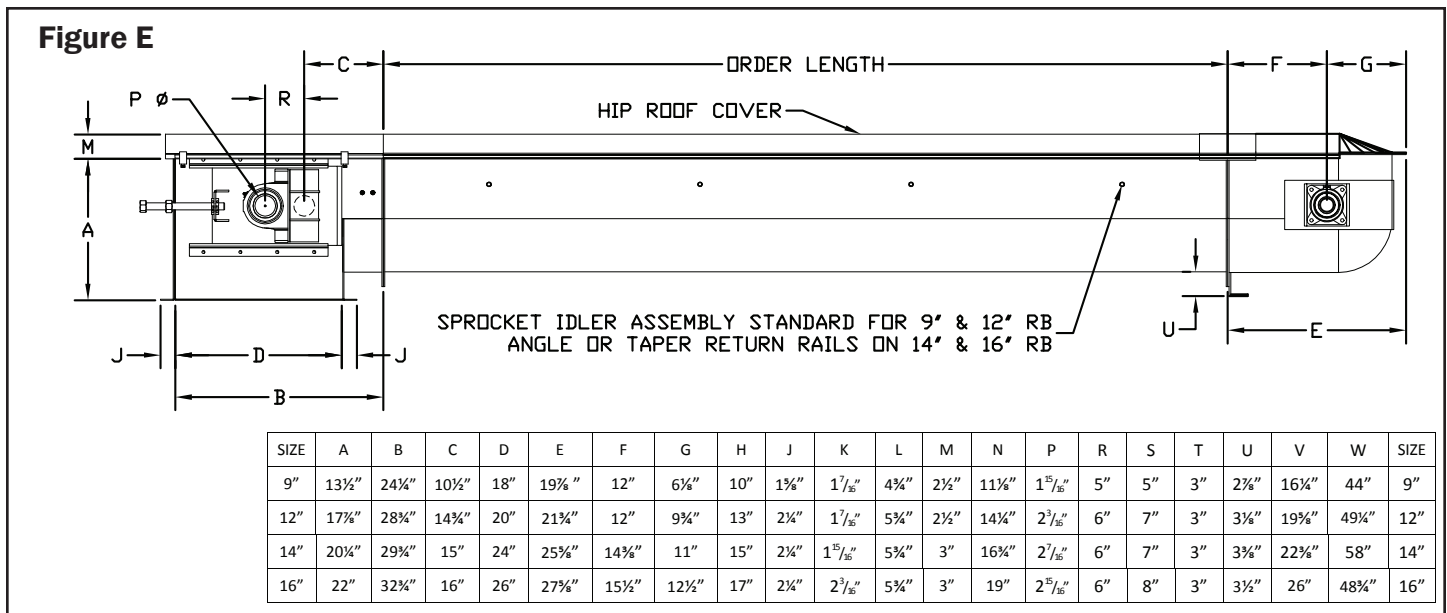

GAUGES & SPECIFICATIONS

HEAD	10 ga.	Pillow Block, Self Aligning Double-Row, Spherical Roller Bearings, Take up for Chain Tension.
TAIL	12 ga.	Flange Block Ball Bearings.
TROUGH	12 ga.std.	10 ga. - 3/16" available.
COVER	14 ga.	Hip Roof.
CHAINS		D88K, D88C

ROUND BOTTOM FLITE-VEYOR® CAPACITY CHART
MODELS 9", 12", 14", and 16"

SIZE	BPH	CFH	BPH	CFH	BPH	CFH
	FPM	MTPH	FPM	MTPH	FPM	MTPH
9"	1000	1250	2000	25000	3000	3750
	66.3	25.4	132.5	50.8	198.8	76.2
12"	3000	3750	4000	5000	5000	6250
	110.4	76.2	147.2	101.6	184	127
14"	4000	5000	5000	6250	6000	7500
	87.1	101.6	108.8	127.0	130.6	152.4
16"	6000	7500	7000	8750	8000	10000
	105	152.4	122.4	177.8	139.9	203.2

Figure F

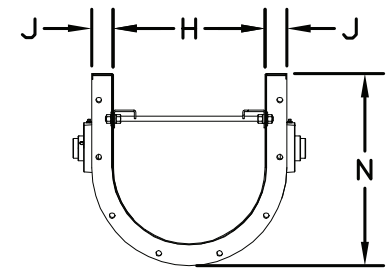

**TROUGH
 CROSS SECTION
 WITH ANGLE RETURNS**

Model	J	H	N
9"	1-5/8"	10"	11-1/8"
12"	2-1/4"	13"	14-1/4"
14"	2-1/4"	15"	16-3/4"
16"	2-1/4"	17"	19"

GENERAL

Only proper installation can offer the performance intended by the manufacturer. Therefore, a good installation should be of prime concern to the customer and to the construction firm responsible for the same. A MANUFACTURER CANNOT BE RESPONSIBLE FOR THE INSTALLATION OF A CONVEYOR. The suggestions and information contained herein are offered solely as a convenience, for we assume no liability as to installation, either expressed or implied.

Unless the location of the equipment has been pre-determined by a layout drawing or print, careful consideration should be given as to the depth of pits, location of inlets, possible obstructions, etc. Plan ahead for the location of supports and bracing.

When the "RB" Flite-Veyor® is used to feed a bucket elevator or another conveyor, provision must be made for proper clearances to allow for drives, discharges, valves, etc. on all equipment. Also, enough clearance should be provided to allow proper maintenance of equipment after it has been installed. Thought given to such matters prior to installation can well prevent later problems in the flow plan and avoid possible "bottlenecks."

Supporting the conveyor on a catwalk requires bolting the unit down to the catwalk every 10 feet as shown in Figure G. These attachment brackets are available from Sweet Manufacturing.

Figure G

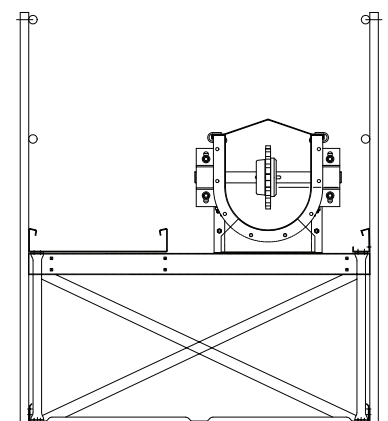

INSTALLATION & ASSEMBLY OF STANDARD CONVEYORS

Layout the unit as it is to be used, including the head and tail section. Do not lift trough lengths greater than 40' with a maximum of 20' between lift points. Support should be at least every section, or a maximum of 10 feet when installed. (See Figure H for typical bottom splice connections.)

Apply silicone caulk to flanges prior to assembly of section. Loosely install the bolts and nuts. Use a taught line to make sure the conveyor is straight horizontally. Shim, as required, to get correct alignment. Tighten the connecting hardware, making sure that the bottom of each section is no higher than the previous section, so that it will not interfere with the chain flights as they move to convey the material. At the time, check the tightness of all the hardware in the conveyor to ensure that all are properly tightened (such as the set screws in the bearings and sprockets.) Conveyor troughs are provided with roller type or angle type chain returns, as specified at the time of order.

Care should be taken to align the heights of angle returns on adjacent sections to prevent the chain flights from catching.

Holes in the trough are oversized, so adjustment can be made by loosening the nuts on the threaded cross-rods that hold the angles in place. Be sure to tighten all hardware after alignment is achieved.

Figure H

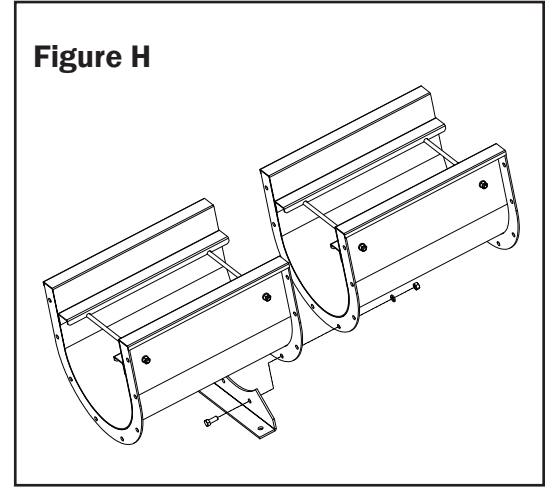

OPTIONAL INTERMEDIATE DISCHARGE

If intermediate discharges are required, the following procedure should be used.

- 1) Determine the location of the center of the intermediate discharge from the tail or head section. Typical intermediate discharge gates are shown in Figure I.
- 2) The trough of the "RB" Flite-Veyor® will need to be field cut to allow the installation of the intermediate discharge gate. Refer to Figure I for a guide line on the holes to cut. Make sure to leave Flite supports in the trough to prevent the Flites from dropping which may result in damage to the chain, "RB" Flite-Veyor® and the drive. Please consult the factory with any questions regarding the cut out for the "RB" Flite-Veyor® intermediate discharge gates.
- 3) The intermediate discharge gate is to be bolted thru the trough at the desired location. The intermediate gate is supplied with a hole pattern. The trough is to be field drilled at the same pattern.

Figure I -
Standard R&P Gate

SIZE	DIM A	# OF CUT OUTS
9'	20'	5
12'	23'	7
14'	27'	7
16'	23'	9

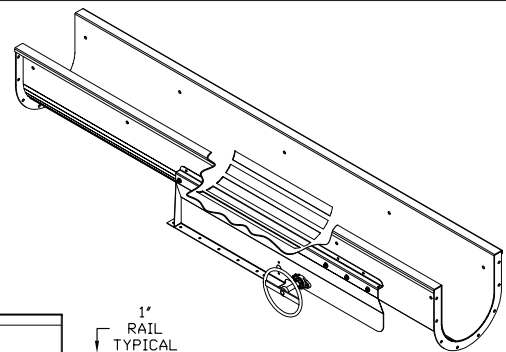
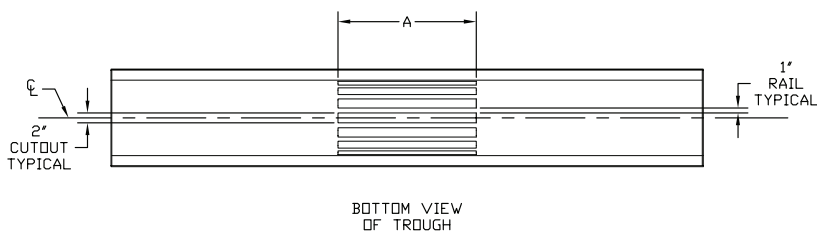

INSTALLATION OF CHAIN

The chain is pre-assembled at the factory. When installing the chain, make sure the head shaft and sprocket are positioned approximately mid position to allow for adjustment after the chain is installed. Be careful to install it with the direction of travel as shown in Figure J.

Figure J

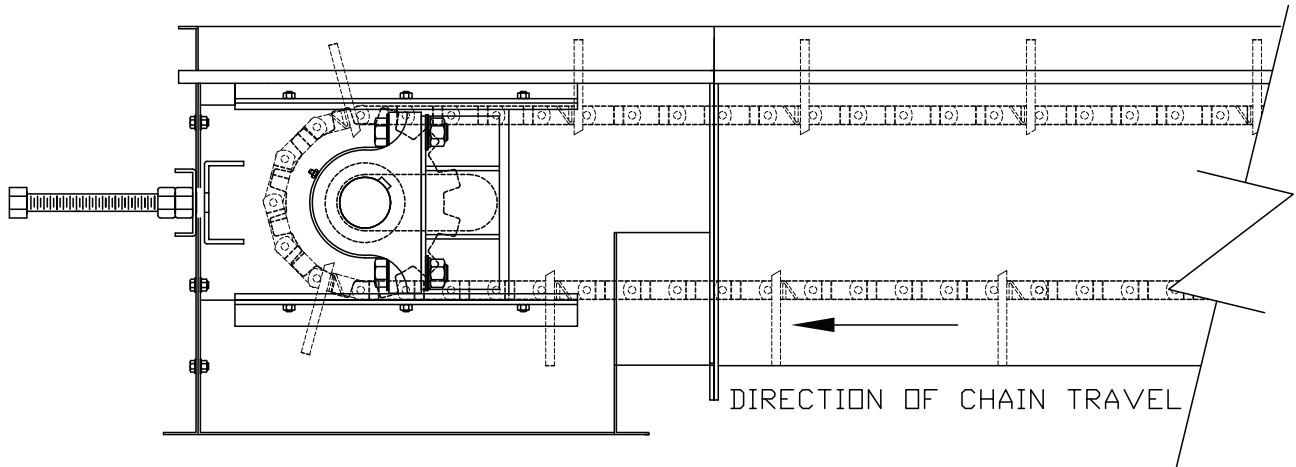

The chain should be placed in the bottom and top of the conveyor and then joined with the connecting pin as shown in Figure K.

Figure K

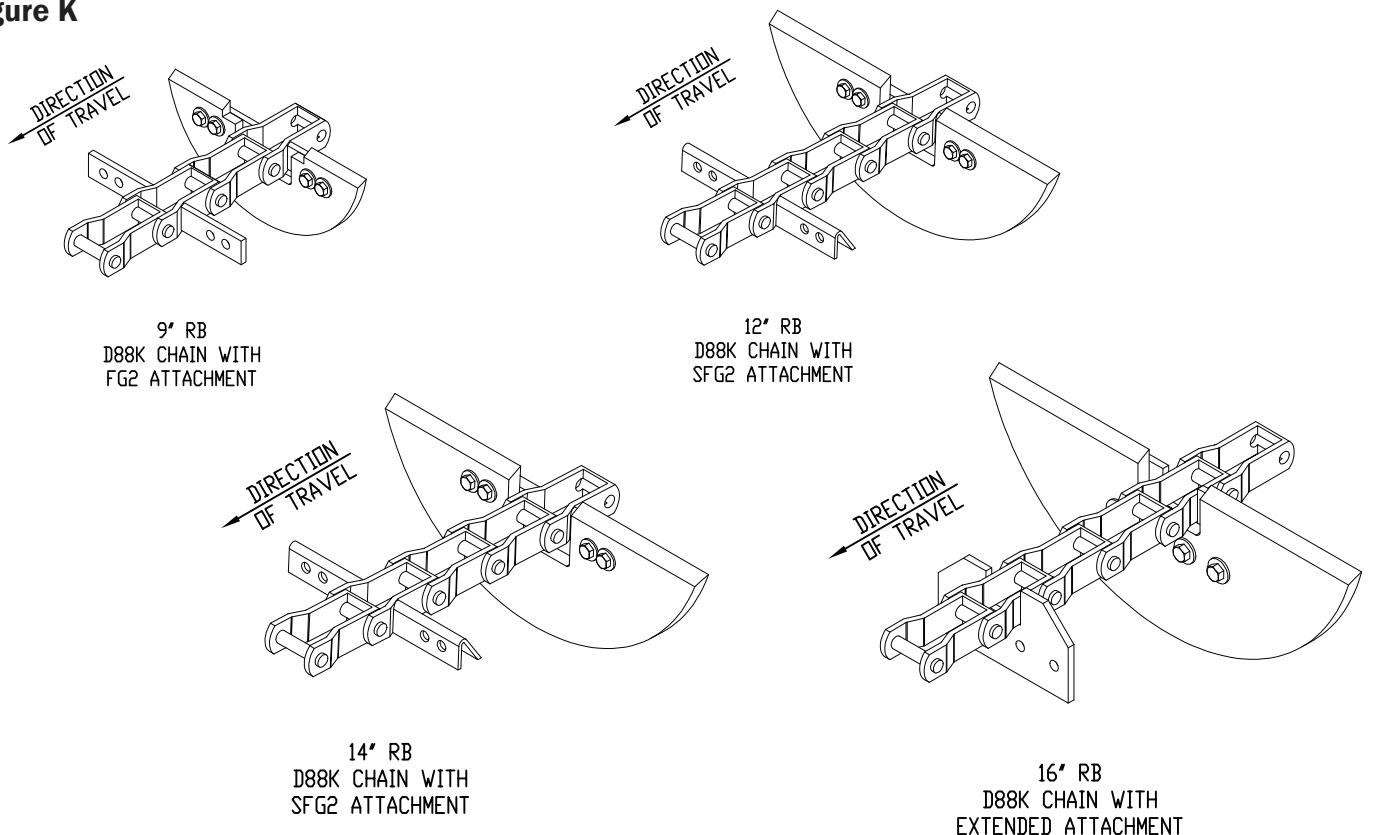

Depending on the chain and the application, the flights should be approximately 13-1/3" apart on the D88K chains. There will be some chain and flighting left over, which should be saved for future use. Adjust shaft and sprocket to tighten the chain on sprocket. Install the trough covers and splice plates before operating. Run for two hours without material. Retighten the chain.

Periodically, the chain will have to be retightened and some links removed. However, the chain should be run with some slack.

CAUTION

Do not run without covers in place on the conveyor or the drive shield. Make sure to add oil to gear reducer before operating, as it is shipped without oil. Follow the instructions with the reducer, making sure not to overfill.

NOTE: OVERFILLING MAY CAUSE DAMAGE TO IMPUT/OUTPUT SEALS AND CAUSE OIL TO LEAK.

CHAIN HANDLING

Chain can become twisted if improperly handled. DO NOT turn over a length of chain by twisting one end, as shown in Figure L. This may cause a permanent twist to the chain.

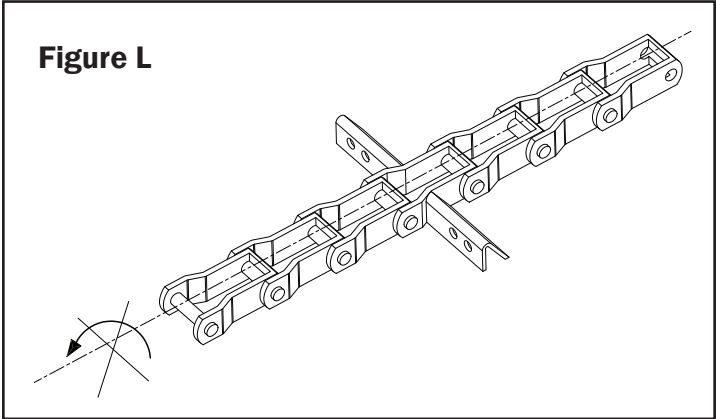

INLET

Field installed inlets should be located as shown in Figure M. However, it can be moved toward the head section as needed. Additional inlets may be added at any point in the conveyor trough. Also, see by-pass inlet in the Options section.

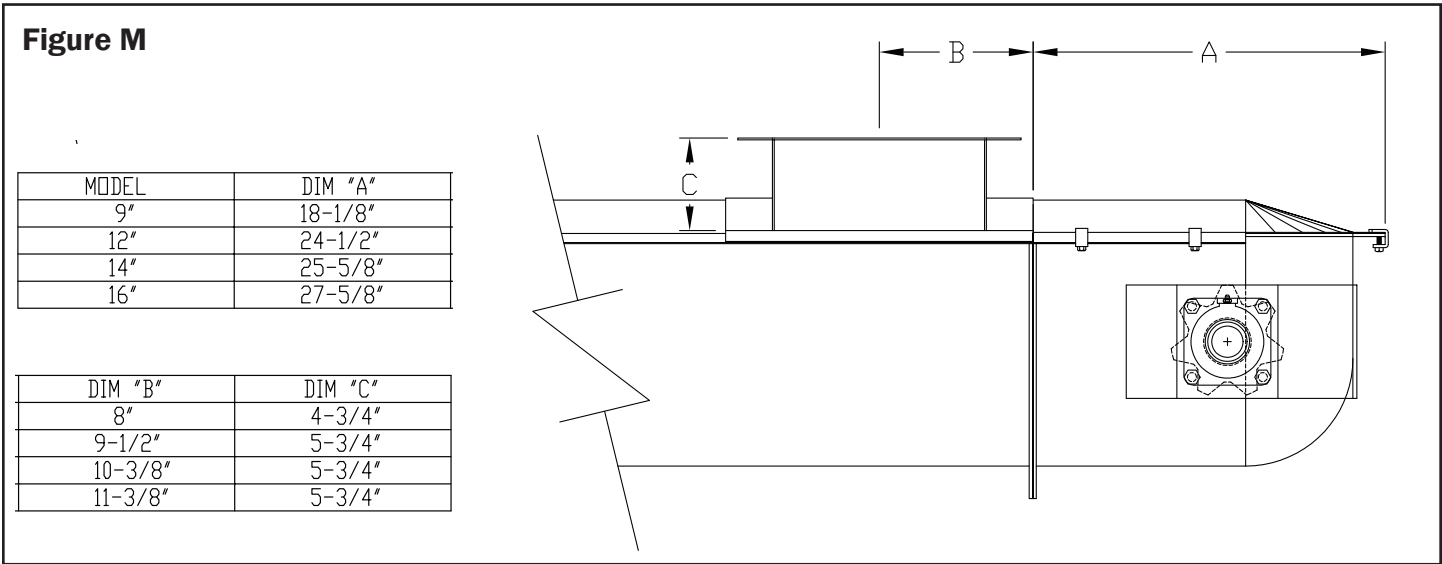

BY-PASS INLET

These inlets are of special design, similar to the pit hopper, which permits bulk material to enter the conveyor between the two chains and relieves turbulence when grain enters the conveyor, therefore reducing damage to the material being handled (see Figure N.) By-pass inlets should be used whenever there is an unregulated head of materials above the inlet, and will add to trough length.

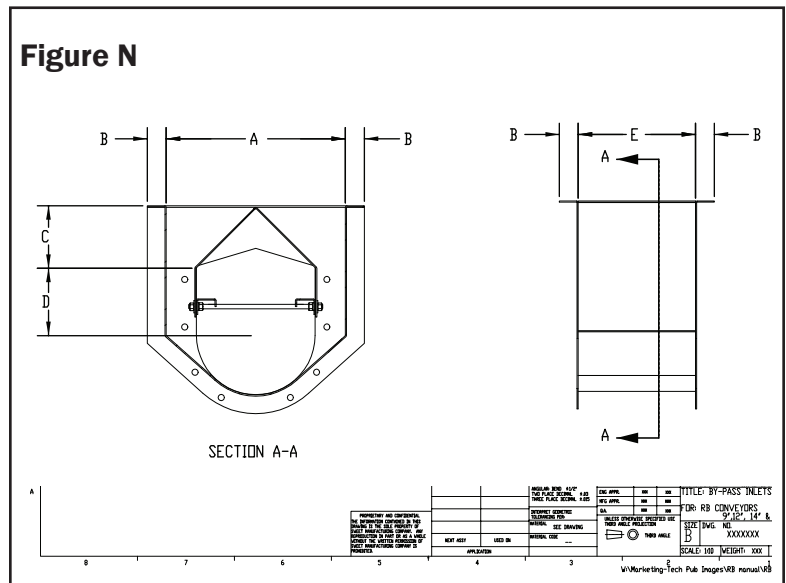

PIT HOPPER

A pit hopper has been developed for use with the "RB" Flite-Veyor®, as shown in Figure O. The grain enters through openings in both sides of the trough and eliminates the drag caused by the top chain moving in the material, greatly reducing the horsepower required for pit applications. A 120" hopper pit opening unit is fabricated in standard 10' trough sections. To determine the additional horsepower required to drive the "RB" Flite-Veyor® with a pit hopper, add 20' to the length of the conveyor. For additional information, consult the Sweet Manufacturing Engineering Department.

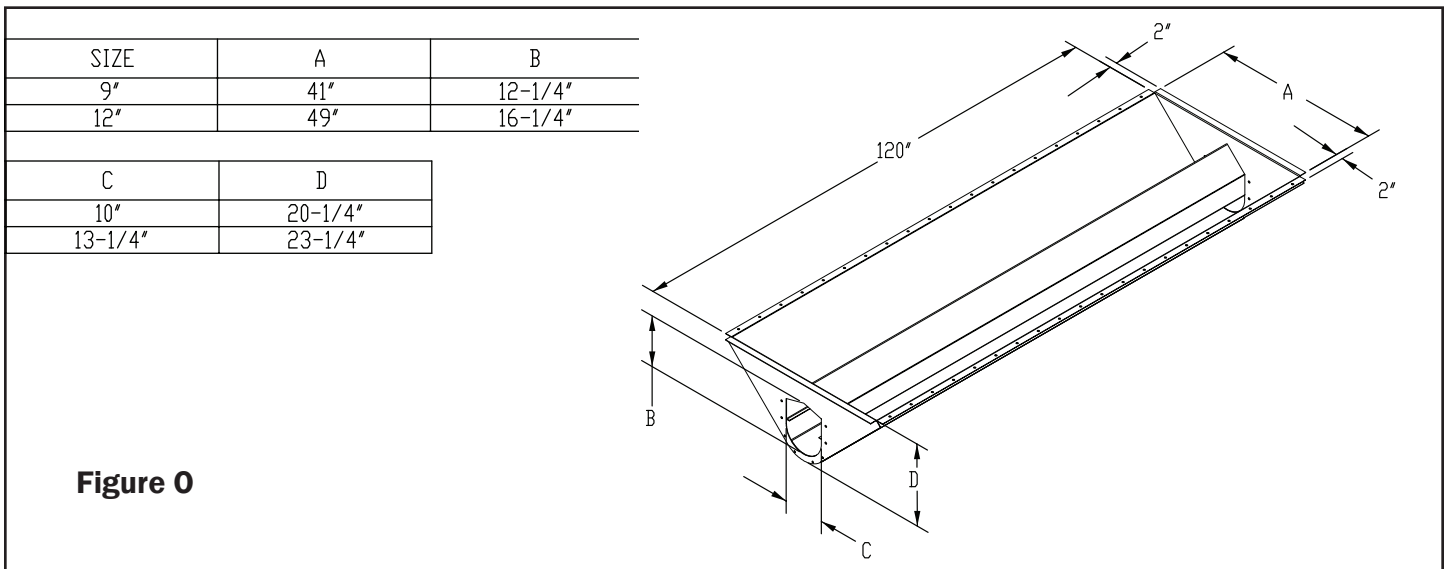

DRIVE ASSEMBLY

The typical drive assembly includes a shaft-mount reducer with torque-arm and reducer bushing, motor mount, sheaves with bushings, V-belts and belt guard. Torque-arm mounting channel (see Figure Q), which bolts to the trough just behind the head section, is supplied on shaft mounted gear boxes up to 50 HP. The standard drive is provided to mount on the left hand side of the head section (when viewing from the tail section). Provisions for right hand drives can be made at the factory, requested at time of order entry.

Proper installation of the speed reducer is essential to provide efficient, economical operation and a long life. Install the reducer as follows:

- 1) Make certain that the driven shaft, on which the reducer is to be mounted, is clean and free from burrs. Remove any protective coating on the driven shaft in the hollow speed reducer. Coatings may be removed by using a non-flammable solvent.
- 2) Inspect and locate machine key in driven shaft.
CAUTION: For safe handling of the reducer, use only proper lifting equipment having ample load carrying capacity. Hand lifting is dangerous. It is good practice to avoid excessive overhung load on both driven shaft and input shaft by mounting reducer as close as possible to bearing support, and the V-belts as close as possible to the reducer. DO NOT force reducer when mounting on shaft, as you may damage the bearings.
- 3) Slide the drive assembly (reducer and motor mount) onto the head shaft.
- 4) When reducer has been properly positioned, secure bushings or set screws against drive shaft. Stake key-seat in drive shaft to prevent key from moving.
- 5) Install the torque-arm on the torque-arm channel on the first trough section, as shown in Figure Q.
CAUTION: Speed reducers are shipped without oil. Be sure to lubricate properly before operation. Refer to the name-plate and service manual for lubrication instructions.
- 6) Torque-arm mounting channel must be welded to bottom of the trough paint or cover weld strip with galvanized paint.

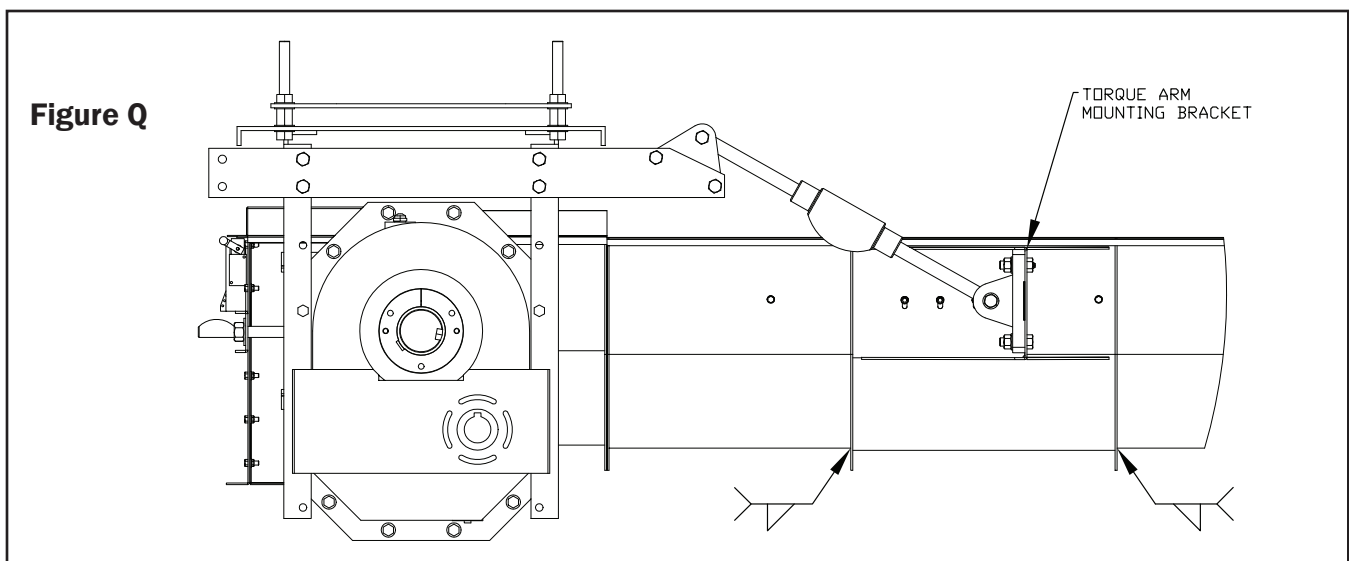

DRIVE ASSEMBLY (CONTINUED)

- 7) **BEFORE INSTALLING THE V-BELTS AND SHEAVES**, install the rear or back side of drive cover and mounting bracket, following the instructions in Figure R. Install proper sheaves on motor and reducer. Check packing list and sheave carton for markings and identification. Interchanging sheaves will result in improper chain speed and unsatisfactory conveyor operation.

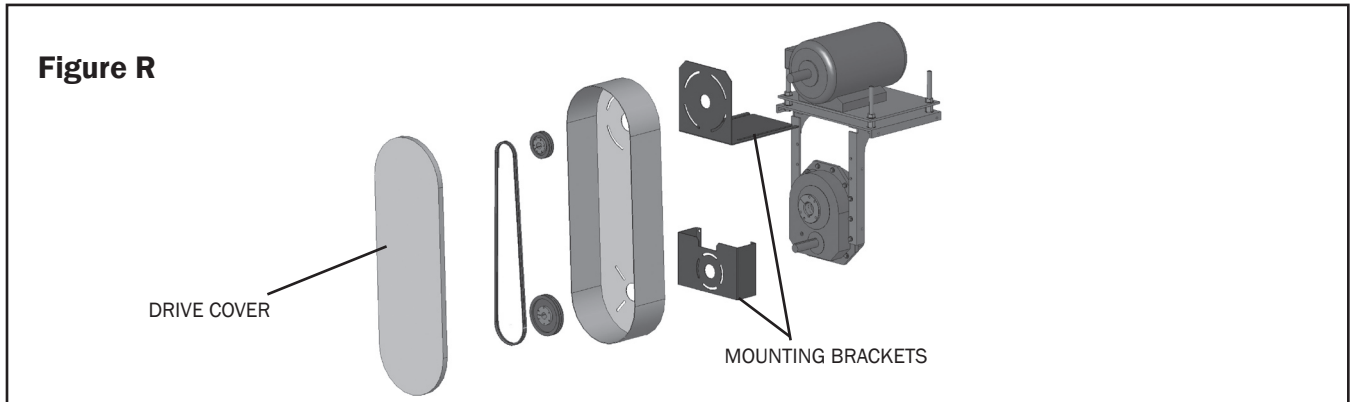

Mount sheaves as close to bearings as possible to minimize overhung loads. Align sheaves by using a straight edge placed across the outer faces of both sheaves. Be sure keys are properly installed and tighten set screw firmly.

NOTE: The head shaft speed may be improper due to installing the wrong sheaves on motor and reducer. Refer to packing list for proper placement of sheaves.

- 8) Install V-belts, tightening them to have 3/8" deflection of the belt with six to nine pounds of force being applied to the belt. V-belts are determined by Figure R mounting configuration.

ELECTRICAL EQUIPMENT

Emergency stop switches, shut-off switches, zero speed switches, overflow and overload devices and other electrical controls are all necessary considerations for a safe conveyor installation. (More controls and switches are usually furnished by conveyor user. However, safety overload switches and zero speed switches can be supplied by Sweet.)

INLET ASSEMBLIES

BY-PASS DUMP HOPPER

The By-Pass Dump Hopper is 10' long. It comes mounted to a 10' trough section and provides a regulated flow of material onto the chain paddles. This reduces material damage, chain shock and horsepower requirements.

BY-PASS INLET HOPPER

The By-Pass Inlet Hopper provides a regular flow of material onto the chain and paddles. By-pass inlet hoppers are field installed.

STANDARD SQUARE FRAME INLET

The Standard (Square Frame) Inlet is mounted directly on top of the conveyor trough. This should only be used where some other means of controlling the flow is above the inlet (e.g., Rack and Pinion discharge). Standard inlets are not recommended as intermediate inlets on an IFV. Use by-pass inlets instead. The standard inlet mounting requires that the middle pan be cut out when being installed on a "RB" Flite-Veyor®.

MAINTENANCE

After approximately ten (10) hours of use, retighten all set screws on the bearings for the head and tail shafts, as well as the bushings on the sprockets and reducer. Check the chain slack in the conveyor and the V-belt tension in the drive. This should be repeated every fifty (50) hours of operation.

LUBRICATION

DO NOT START UNIT WITHOUT FIRST FILLING REDUCER WITH OIL!

SPEED REDUCER

The shaft mounted speed reducer is lubricated by an oil reservoir in the housing. The correct amount of oil is important to the proper operation of the reducer. Too much oil may cause leakage or overheating. Too little oil may cause overheating or damage to internal parts. The "Speed Reducer Service Instruction Manual" gives a list of recommended lubricants and oil change periods.

DO NOT USE lubricants of the EP (extreme pressure) type, those containing slippery additives or heavy weight (90-140 wt.) gear lube. It is recommended that oil be drained and housing flushed after the first 150 hours of operation and that the oil be changed every 2500 hours thereafter. Check oil level occasionally when unit is not operating and add as required.

Keep breather holes clear at all times to prevent pressure buildup in reducer.

WARNING!!

NEVER remove breather plug or oil level plug while drive is in operation or personal injury may result. Check these only when drive is not operating.

INSPECTION

An inspection schedule should be established in order to ensure that the equipment is in good operating condition at all times. Regular inspections will help to reveal little things such as loose bolts, damaged paddles, etc., before they become serious and damaging problems. Here are some of the things which should be inspected and maintained regularly.

- 1) Inspect chain and paddles for loose bolts, damaged flights and chain condition.
- 2) Check chain tension; remove necessary links if it cannot be adjusted further.
- 3) Inspect V-belts for tension and condition. V-belts should be replaced with a MATCHED SET.
- 4) Check speed reducers regularly for sufficient oil and signs of leakage. KEEP BREATHERS CLEAN.
- 5) Check bearings for sufficient lubrication and evidence of overheating.
- 6) Check all sheave and drive attaching parts for sufficient tightness.
- 7) Check all hardware and tighten as required.

SAFETY

WARNING!

Make inspections when all operations are stopped and lockout and tagout procedures are completed. The importance of exercising EXTREME CARE when erecting and maintaining a Flite-Veyor® cannot be over emphasized. Working at heights reached by even the smallest installations can be hazardous unless safety precautions are taken. In any case, BE CAREFUL - DO NOT HURRY - AND REMEMBER WHERE YOU ARE AT ALL TIMES.

Your conveyor has been designed to comply with CEMA safety standards. These safety standards can be obtained through the American Society of Mechanical Engineers as ASME B20 (1993).

Operating and maintenance personnel should be thoroughly trained in safe operating procedures, recognition of possible hazards and maintenance of a safe area around the conveyor.

Shown at right is an example of the warning sign attached to drive guard:

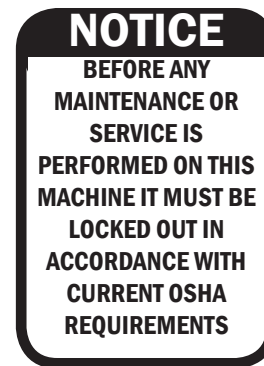

The following safety guidelines should be followed:

THESE ARE GUIDELINES ONLY AND COMPLIANCE WITH SAFETY STANDARDS - LOCAL, STATE AND FEDERAL, INCLUDING OSHA - IS THE RESPONSIBILITY OF THE USER.

- 1) Maintain a safety program for all operating personnel.
- 2) All operating personnel should be advised of the location of all emergency controls and devices.
- 3) Good lighting, housekeeping and maintenance contribute to a safe work area.
- 4) Frequent inspections should be made on all conveyor equipment and all safety devices should be in position and in proper working order.
- 5) Conduct a pre-startup safety check of all conveyor equipment to determine that the machinery and area are safe for operation and that guards and warning devices are in place.
- 6) There should be absolutely NO reckless actions or horseplay in the vicinity of conveyors. Most accidents are caused by lack of proper safety training, carelessness, horseplay and lack of awareness of possible hazards.
- 7) Conveyors should not be operated unless the conveyor housing completely encloses the moving elements and power transmission guards are in place. If the conveyor cover or housing is to be opened, the motor must be locked out / tagged out electrically in such a way that it cannot be restarted by anyone in the vicinity or remote from the conveyor. Overflow cover sections or doors should not be opened while the conveyor is operating.
- 8) If, because of its application, the conveyor must have open housing, then the entire conveyor must be separated from personnel areas by a fence and warning signs posted.
- 9) Open feed hoppers or spouts for shovel, front end loaders or their manual or mechanical loading must incorporate a grating. If the characteristics of the material being handled are such that a grating cannot be used, then the exposed portion of the conveyor must be guarded by a fence and warning signs posted.
- 10) DO NOT walk or stand on the conveyor cover, grating or power transmission guards.



Our Mission

***To provide innovative quality solutions that create
an extraordinary customer experience.***