

CALORMATIC®

MULTI-PURPOSE HEAT PROCESSOR WITH PLC

Installation and Operation Manual

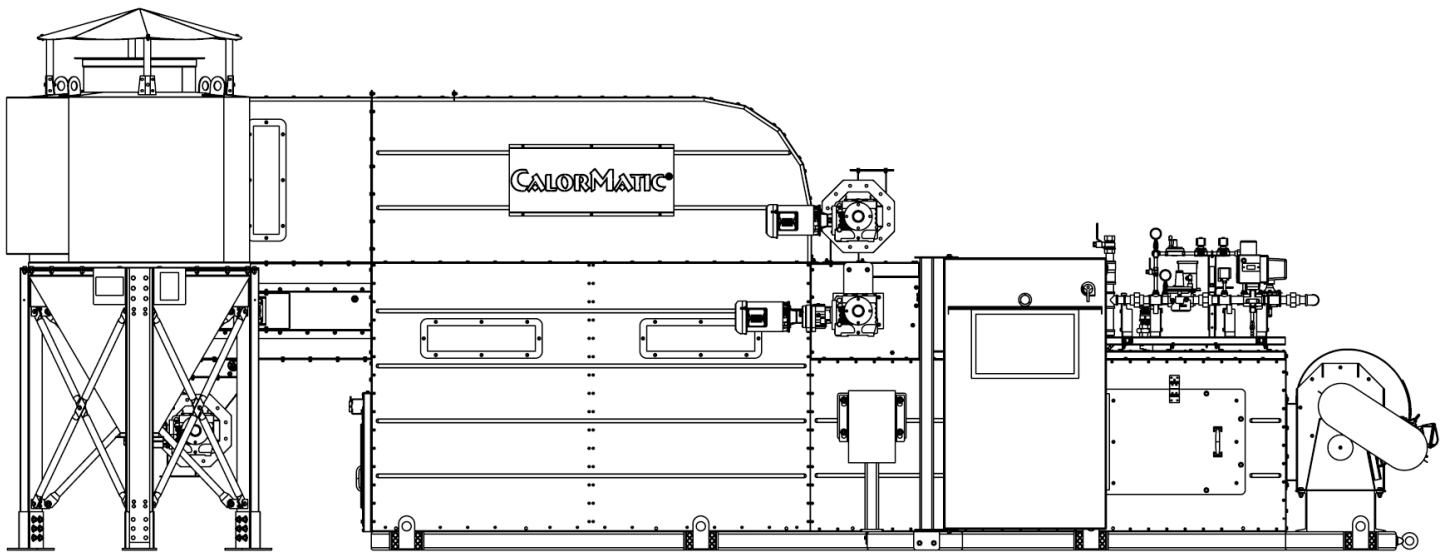

MANUFACTURING COMPANY

2000 East Leffel Lane · Springfield, Ohio 45505

Phone +1 (937) 325-1511 · Email: sales@sweetmfg.com

www.sweetmfg.com

THIS MANUAL IS THE PROPERTY OF:

MODEL: _____

SERIAL NUMBER: _____

DATE PURCHASED: _____

WARRANTY

All items manufactured by Sweet Manufacturing Company are warranted against defects in material and workmanship for one (1) year from the date of shipment (but not against damage caused by accident, abuse, or faulty installation). Sweet Manufacturing Company will repair or replace free of charge (F.O.B. point of supply) all such defective parts if returned to the factory, charges prepaid. No allowances will be made for repairs, alterations or changes unless specifically authorized by us. There are no other warranties expressed or implied other than title, freedom from liens, and against patent infringement. **Seller makes no warranty of merchantability or fitness for a particular purpose.**

Limitation of Liability - Liability of Sweet Manufacturing Company to the purchaser for damages arising out of the manufacture, sale, delivery, use or resale of the equipment, whether based on warranty, contract, negligence, or otherwise shall be limited to and shall not exceed the cost of the repair or replacement of the defective part or parts. Upon expiration of the warranty, all such liabilities shall terminate. The Seller shall not be liable to the purchaser or user, for loss of anticipated profits, loss by reason of plant shutdown, non-operation, or increased expenses of operation of other equipment or other consequential loss of damage of any nature arising from any cause whatsoever by reason of the manufacture, sale, delivery, use, or resale of the equipment covered by this order or contract.

CHECK AND INSPECT YOUR ORDER

Each order or shipment is double-checked before leaving the factory. All parts, pieces and components are listed item by item on our packing list, which accompanies each order. The number of each item, package, container, skid, etc. is listed on the bill of lading. In signing the bill of lading, the carrier assumes full responsibility for the safe delivery of all goods to destination in the same order a carrier was tendered by the shipper. In the event of damage or shortage, have the transportation company note the same on the freight bill. You should then file claim against the carrier for such loss and/or damage.

You will find a packing list attached to one of the items in the shipment. Check each item against the list. Check by description, specification, quantity or count, etc. Should there be any discrepancies, notify us immediately. If an order or shipment includes more than one heat processor, the parts for each order will be keyed or marked on the packing list for easy identification.

IMPORTANT - In addition to checking items and count included in shipments, it is also important to inspect and check shafts, bearings, pulleys and sprockets having set screws. Movement, vibrations and handling in shipment may loosen set screws and bolts.

Small parts and items, such as bolts, washers, bushings, and keys are just as important to an installation as the larger parts. Make sure these are located and checked before disposing of any containers or packing. We cannot be responsible for the loss of items that are listed and included on our packing list.

Should there be some delay between the time an order is received and ensuing installation, store parts in a protected area so they may be easily located and identified. Retain packing lists for this reason, as well as for future parts reference.

GENERAL INSTALLATION

The installation guidelines mentioned, along with the drawings for the model you purchased, are intended to assist in planning your final installation procedures. Procedures will vary among installers. When unsure of the proper installation procedure, we recommend that you contact our office for assistance if you do not find a recommended procedure in this manual.

The best equipment, improperly installed, cannot be expected to provide the performance intended by the manufacturer. Therefore, a quality installation should be of prime concern to the customer and installing contractor. Sweet Manufacturing Company is NOT responsible for the installation of a heat processor. The suggestions and information contained herein are offered solely as a convenience. We assume no liability for poorly installed equipment, whether that liability is expressed or implied.

1. It is important that a firm and level foundation be provided on which to install a CalorMatic®. The footing should be ample to carry the load of the heat processor, and be free of water. The foundation can be at ground level or elevated on supports.
2. All electrical wiring should meet necessary code requirements.

CalorMatic®

INTRODUCTION

The purpose of this manual is to assist owners and operators of heat processors in the installation, operation and maintenance of their equipment. You have purchased a quality designed product which has been manufactured with utmost care using fine materials and reflecting many years of engineering knowledge.

THE FOLLOWING INFORMATION IS INTENDED TO AID YOU IN THE INSTALLATION AND OPERATION OF YOUR NEW CALORMATIC®. TO ENSURE LONG LIFE AND TROUBLE-FREE OPERATION, WE RECOMMEND THAT YOU READ AND FOLLOW THESE INSTRUCTIONS CAREFULLY AND PROVIDE REGULAR, PERIODIC MAINTENANCE.

IT IS THE INSTALLER'S RESPONSIBILITY TO BE AWARE OF AND TO COMPLY WITH ALL LOCAL CODE REQUIREMENTS, INCLUDING BUT NOT LIMITED TO GAS AND ELECTRICAL CODES.

TABLE OF CONTENTS

Check & Inspection / General Installation	1
Introduction	2
Operational Concept	3
Safety Requirements	4
Initial Set-Up Procedure	6
Start Up Procedure	8
Burner System Sequence of Operation	16
Sequence of Operation	17
Flame Sensing Systems	18
Control Panel Explanation	19
Maintenance	21
Troubleshooting Chart	22
Troubleshooting Procedures	23
Parts List	25
Factory Inspection Checklist	26
Training Sheet	28

OPERATIONAL CONCEPT

The CalorMatic® heat processor utilizes a fluidized bed of hot air (up to 600° F) to roast, toast, condition, and/or remove moisture from many different products. The ‘processed’ air is collected by cyclones to provide for separation of particulates from the air stream. The product infeed and discharge are by rotary valves, providing environmental control.

The CalorMatic® offers several variable parameters to allow users to process materials to reach their optimum final condition. These variables include operating temperature, infeed rate, exposure time, and airflow rate. Adjustments allow maximum throughput and efficiency while obtaining the optimum physical properties desired.

A centrifugal fan supplies a high volume of air at minimal sound levels. The air is heated by a burner located just downstream of the fan, in an air plenum designed to prevent direct flame contact with the product. Heated air passes through the product at high velocities, fluidizing the product to provide thorough mixing for even processing.

The desired air temperature is selected by the operator and controlled by a modulating gas valve. Sensors monitor the presence of air and flame, as well as the temperature of the heated air and processed product.

The product is fed into the processing chamber through a rotary valve, which has a variable speed drive. Adjusting the speed of the rotary valve allows the operator to determine the optimal depth of material as related to processing speed and amount of fluidization desired.

The product is moved through the processing chamber by a drag chain conveyor. The conveyor speed is adjustable, allowing the operator to control the time of product exposure. The product is discharged through another rotary valve.

Typical Operating Parameters

Product	Air Temperature	Product Temperature	Chimney Temperature	Gas Pressure	Product Depth
Soybeans	570° F	285° F	325° F	30" WC	4" - 5"
Egg Shells	600° F	300° F	350° F	30" WC	4" - 5"
Corn	425° - 470°	300° F	500° F	30" WC	4" - 5"

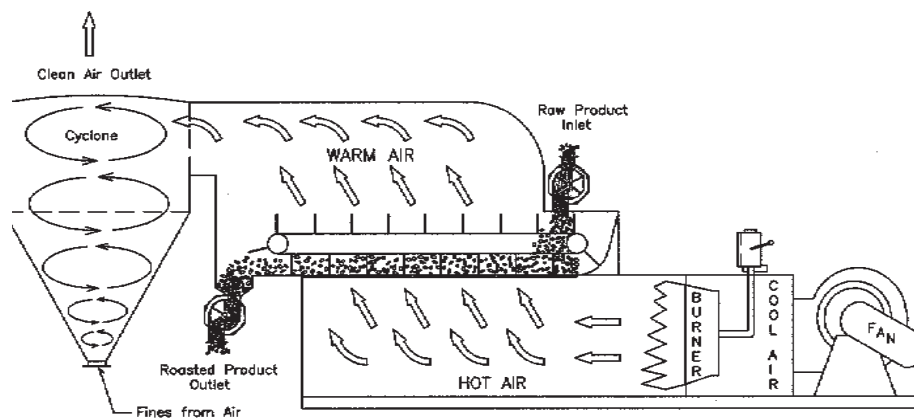

CalorMatic®

SAFETY REQUIREMENTS

Operating and maintenance personnel should be thoroughly trained in safe operating procedures in order to recognize possible hazards, and to maintain a safe work area around the CalorMatic®.

The following safety guidelines should be followed:

1. Maintain a safety program for all operating personnel.
2. All operating personnel should be advised of the location of emergency controls and devices.
3. Good lighting, housekeeping and maintenance contribute to a safe work area.
4. Frequent inspections should be made of all equipment. All safety devices should be in proper working order.
5. Conduct a pre-start safety check of all equipment to determine the machinery and surrounding area are safe for operation and guards and warning devices are in place.
6. Equipment should not be operated unless all exposed moving parts are properly guarded. If the CalorMatic® cover or housing is to be opened, the motor and equipment must be locked out electrically in such a way that it cannot be restarted by anyone. Inspection doors should not be opened while the machine is operating.
7. * NEVER bypass or “jumper” any electrical safety circuits, except during troubleshooting while machine is shut down.

THESE ARE GUIDELINES ONLY AND COMPLIANCE WITH SAFETY STANDARDS, LOCAL, STATE AND FEDERAL, IS THE RESPONSIBILITY OF THE USER.

ELECTRICAL SAFETY EQUIPMENT

Emergency stop switches, safety shut-off switches, zero speed switches, overflow and overload devices, bin full and/or bin empty switches and other electrical controls may be required for a safe CalorMatic® installation. These auxiliary controls are to be furnished by the equipment user, as needed.

* Troubleshooting to be performed by qualified personnel only.

WARNING!



ROTATING FAN BLADE
COULD CAUSE
SEVERE INJURY
LOCKOUT POWER BEFORE
REMOVING COVER OR
INSPECTION DOOR

EMC 21 64

WARNING!



MOVING PART
CAN CAUSE
SEVERE INJURY
LOCK OUT ENERGY
SOURCE BEFORE
INSPECTION OR SERVICE

EMC 30 64 EFVGG

! NOTICE !

BEFORE ANY
MAINTENANCE OR
SERVICE IS
PERFORMED ON THIS
MACHINE IT MUST BE
LOCKED OUT IN
ACCORDANCE WITH
CURRENT OSHA
REQUIREMENTS

EMC 402 406 00 V6

Your CalorMatic® is provided with safety decals to warn you of potential hazards. READ AND OBSERVE all of OSHA safety warnings. If decals become damaged or are removed, please contact Sweet Manufacturing Company for replacements at:

+1 937-325-1511
Please have your
serial number available.

WARNING!



HOT SURFACES
CAN CAUSE
SEVERE BURNS
AVOID CONTACT LOCK
OUT ENERGY SOURCE
BEFORE SERVICING

EMC 34 43

WARNING

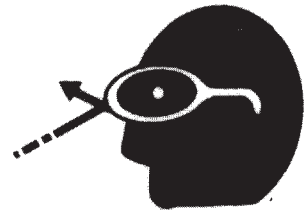

FLYING MATERIAL CAN
CAUSE SEVERE EYE
INJURY OR BLINDNESS
WEAR SAFETY
GLASSES AROUND
OPERATING EQUIPMENT

EMC28 44 18 V6

WARNING!



EXPOSED CONVEYORS
AND MOVING PARTS CAN
CAUSE SEVERE INJURY
LOCK OUT POWER BEFORE
REMOVING COVER OR
INSPECTION DOOR

EMC 27 406 00 V6

! DANGER !

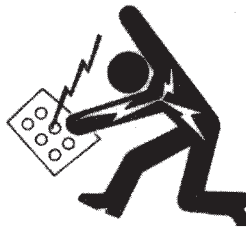

HAZARDOUS VOLTAGE
WILL CAUSE SEVERE
INJURY OR DEATH
TURN OFF POWER
AND LOCK OUT
BEFORE SERVICE

EMC 11 46 18 VGG

WARNING!



EXPOSED BELT CHAIN
& MOVING PARTS CAN
CAUSE SEVERE INJURY
LOCK OUT
POWER BEFORE
REMOVING GUARD

EMC 24 46

INITIAL SET-UP PROCEDURE

1. Before applying electrical power to machine, be sure transformer in control panel is wired to match incoming line voltage.
 2. Pilot line gauge should read 5 PSI nominal pressure. See gas train assembly drawing for pressure line reference.
 3. It is also recommended to remove electrical box cover on motor and recheck motor connections to ensure line voltage matches motor connections.
 4. Set low gas pressure switch to 10" W.C. (Hawk and Eagle)
 5. Set high gas pressure switch to 35" W.C. (Hawk and Eagle)
 6. With fan off, press Reset on "Plenum high limit" and verify that limit does not appear on display. If limit shows, see troubleshooting. With panel door open, turn ignition switch on and verify that indicator light is illuminated (flashes). If not, see troubleshooting.
 7. Check temperature readings on controllers for consistency.
 8. Press DISP button on High Limit - verify setting (600° F / 315° C MAX) - press reset.
 9. Pressure test all gas piping; use soapy water to test all connections for gas leaks.
WARNING: Never test for leaks with a match or open flame! Correct any leaks before proceeding.
 10. Make final check for any obstruction inside heat processor; material flow in, material flow out.
CAUTION: Never move product through the conveyor when the fan is off.
- *3 & 4 - Check that low and high gas gauge is set as indicated on gauge (refer to photo below).

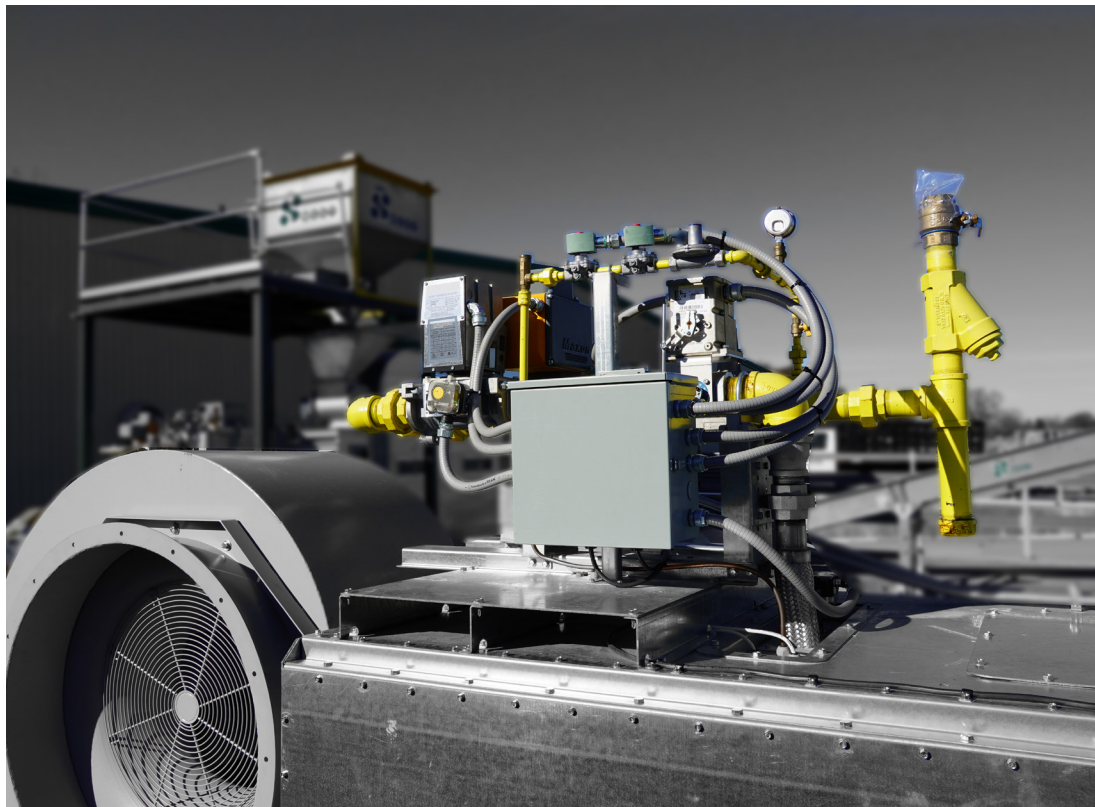

Gas Train Assembly

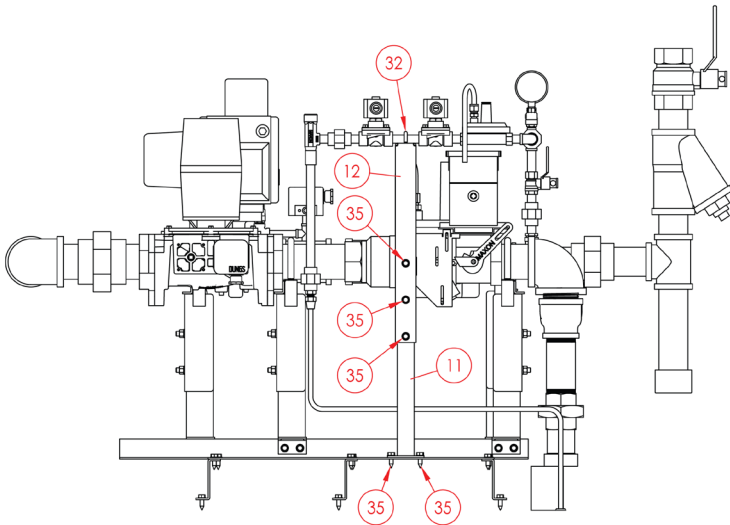
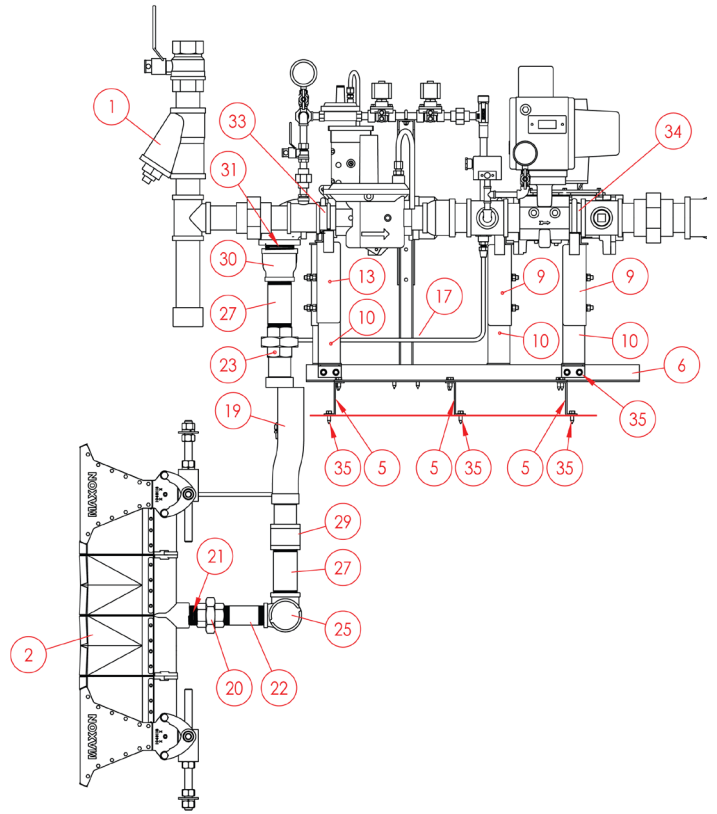
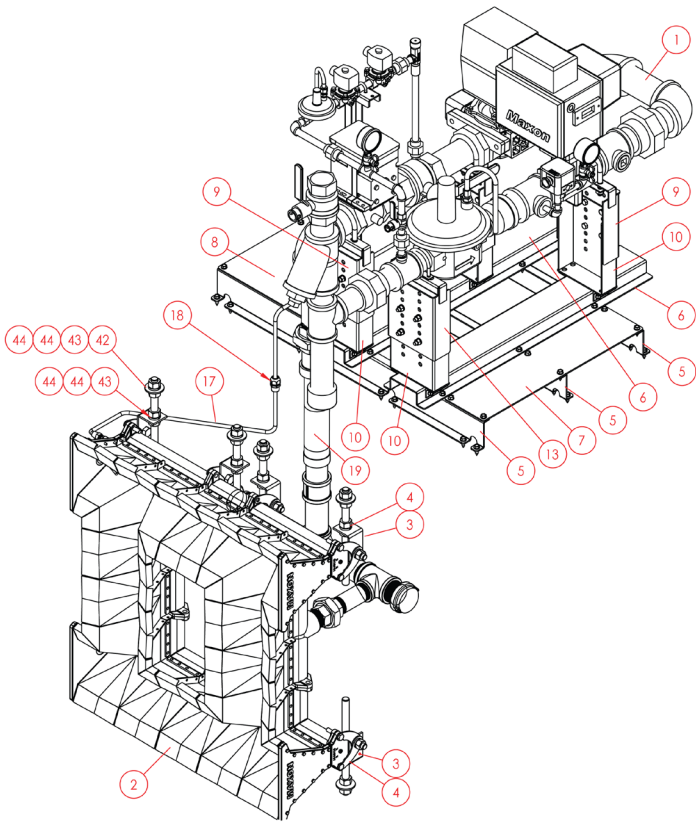

SECTION A-A
SCALE 1 : 8

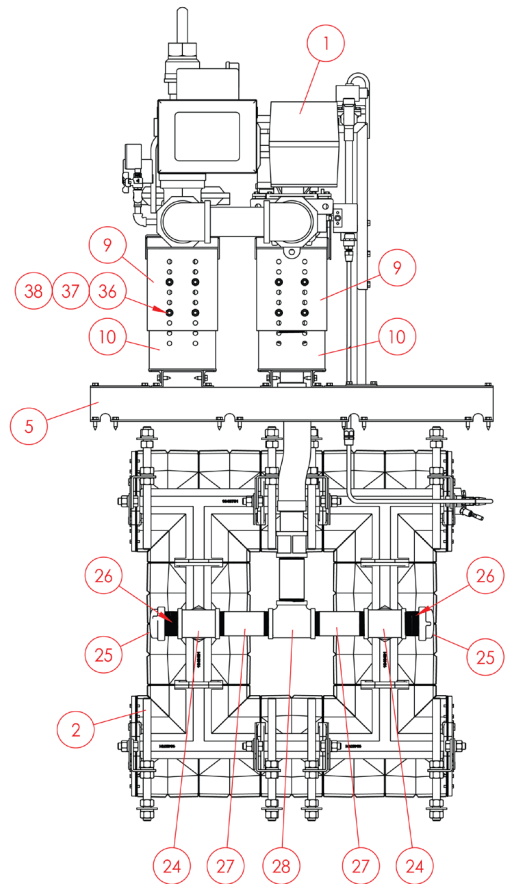

ITEM #	PART #	DESCRIPTION	QTY.
1	0948807	GAS TRAIN,10.5M BTU,"D,60H,EAGLE II	1
2	0951039-LE	LINEBURNER ASM, 10.5M BTU/HR NP-I-LE,ALUM	1
3	0953126	BRACKET,BURNER MOUNT,CARDINAL I THRU EAGLE IV,3/16"GALV.	8
4	0950057	ROD,BURNER MOUNTING,CALOR., Ø 3/4"-10	8
5	0948790	STIFFENER, TOP BURN PLENUM,EAGLE I/II	3
6	0948791	MNT.RAIL,ADJ.MNT.GAS TRAIN,EAGLE I/II	2
7	0948899	PLATE,MNT.ELEC.COMP.EXTERNAL,EAGLE 2	1
8	0948899R	PLATE,MT.,ELEC.COMP.,RH,EXT.COMP.,E2,10GA.GALV.	1
9	0948895	WELD'T,UPPER ADJ.MNT.GAS TRAIN,2-1/2" PIPE	3
10	0948797	WLDT.,LOWER,ADJUSTABLE MT.,GAS TRAIN,EAGLE I/III/IV	4
11	0953246	WLDT.,LOWER,ADJUSTABLE MT.,PILOT,GAS TRAIN,BJ	1
12	0953743	CHNL.,UPPER,ADJUSTABLE MT.,PILOT,GAS TRAIN,H-E4,10GA.GALV.	1
13	0948898	WELD'T,UPPER ADJ.MNT.GAS TRAIN,EAGLE 2	1
14	0957905	BRASS CONNECTOR,3/8"X3/8"MPT LF	1
15	0957907	FLARE NUT,BRASS, 3/8"	2
16	0957906	BRASS CONNECTOR,3/8"X1/4"MPT LF	1
17	0001805	COPPER TUBING, SOFT, 3/8 OD	6'
18	0950834	XP CONNECTOR, STRAIGHT, 1", ST100	3
19	0950563	FLEXIBLE TUBING SS304 18"OAL/12"FLEX 2"	1
20	0950530	PIPE UNION 1-1/2" DIAMETER BLACK	2
21	0950512	PIPE NIPPLE,CLOSE, BLACK IRON, 1-1/2"DIA	2
22	0957650	PIPE NIPPLE,BLACK IRON,1-1/2"DIA X 5"LG	2
23	0451316	PIPE UNION 2" DIA. BLACK IRON	1
24	0950579	PIPE TEE,2" X 2" X 1-1/2" BLACK IRON	2
25	0957068	PIPE CAP,BLACK IRON,2"DIA.	2
26	0950508	PIPE NIPPLE,CLOSE, BLACK IRON, 2"DIA	2
27	0451326	PIPE NIPPLE,BLACK IRON, 2" DIA X 6" LG	4
28	0950504	PIPE TEE,2" X 2" X 2" BLACK IRON	1
29	0451317	PIPE COUPLING 2" DIA. BLACK IRON	1
30	0957810	PIPE,REDUCING COUPL,ROUND,2-1/2"TO 2"	1
31	0957269	PIPE NIPPLE,CLOSE, BLACK IRON, 2-1/2"DIA	1
32	0951996	U-BOLT,1/4"-20,F/3/8"PIPE,1-1/4"HT, ZP	1
33	0451469	U-BOLT,5/16-18,#15,F/2"PIPE,3-3/16"L	1
34	0451743	U-BOLT,1/2"-13,F/2-1/2"PIPE,4-1/2"HT, ZP	3
35	0404910	SHEET METAL HWH SCREW,ZINC,5/16"-18 X 1	71
36	0400082	HEX HEAD BOLT, ZINC, GR5, 3/8"-16 X 1"	16
37	0455182	LOCKWASHER, SPLIT RING , ZINC, 3/8"	16
38	0400552	HEX NUT,ZINC,GR2, 3/8"-16	16
39	0400162	HEXHEAD BOLT,ZINC,GR5 5/8-11 X 1-1/2"	8
40	0400514	LOCKWASHER, SPLITRING, ZINC, 5/8	8
41	0400554	HEX NUT, ZINC, GR5, 5/8-11	8
42	0400525	FLATWASHER,TYPE A,WIDE,ZINC, 3/4"	8
43	0400515	LOCKWASHER, SPLITRING, ZINC, 3/4"	16
44	0400555	HEX NUT, ZINC, GR5, 3/4"-10	32

CalorMatic®

START UP PROCEDURE

1. Inspect unit
 - Ensure all doors are closed and secured
 - Ensure the plug chute paddle swings freely
 - Ensure the airbed is empty
 - Ensure the plenum is empty
2. Turn main power switch (1) to the 'ON' position.
 - HMI Screen should power up and run self-checks
 - Nothing should be moving (Blower, Chain, Inlet, or Outlet)
3. Touch the green Reset/Fault Arrow in bottom right corner

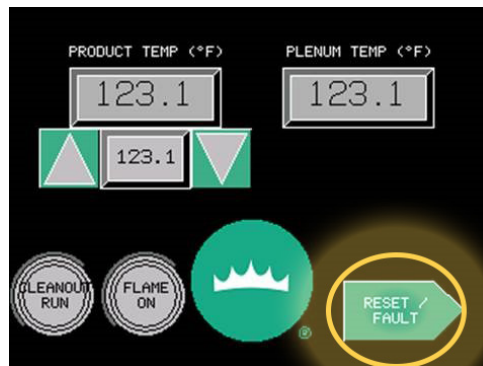

4. Touch the green Run/Cleanout Arrow in bottom right corner

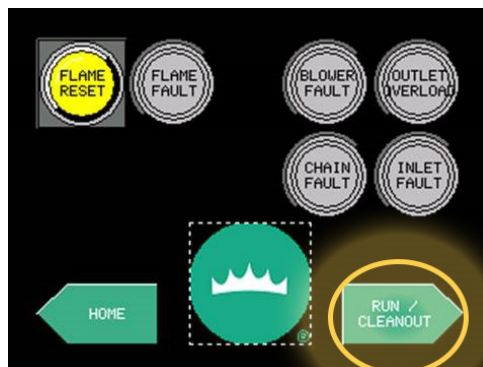

5. Touch the green Blower/Outlet Arrow in bottom right corner

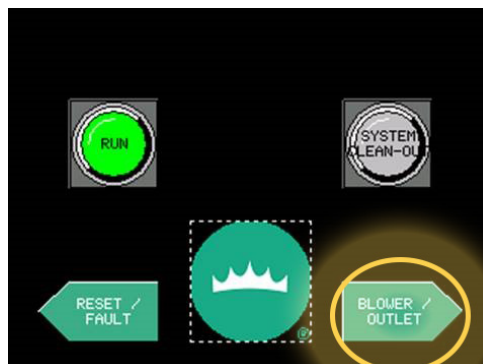

6. Adjust Blower to 30 Hz, either by manually scrolling with the Arrow Buttons or touching the box and typing in the actual number. Touch the Start Button
 - You will hear the Blower Fan begin to turn and speed up

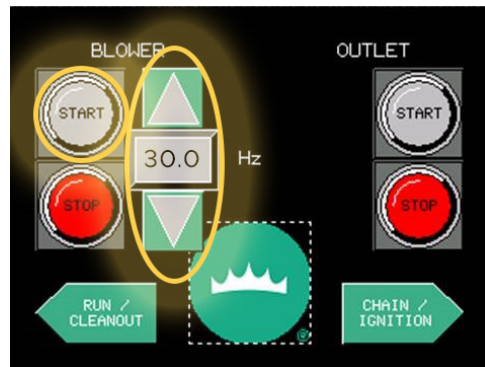

7. Start the Outlet
 - You will hear the Rotary Outlet begin to turn

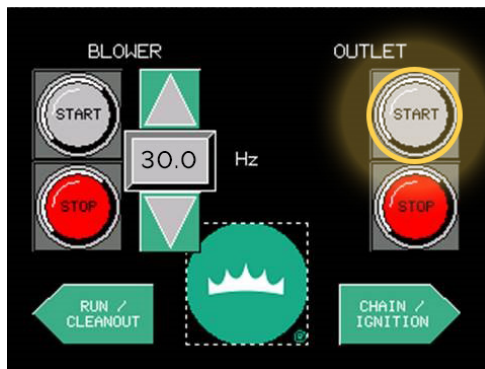

8. Touch the green Chain/Ignition Arrow

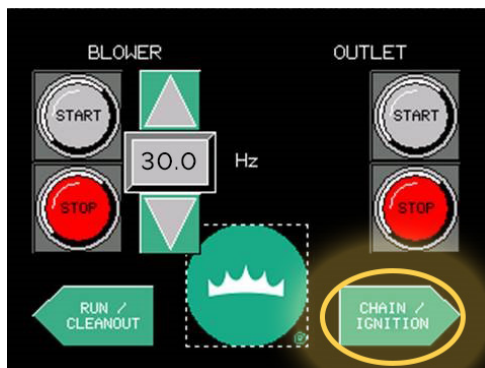

9. Touch the Ignition Start Button
 - There is a 10 second System Purge
 - There is a 10 second Flame Detection Sequence
 - Then you will hear the Main Burner fire. You can also confirm by looking through the burner window

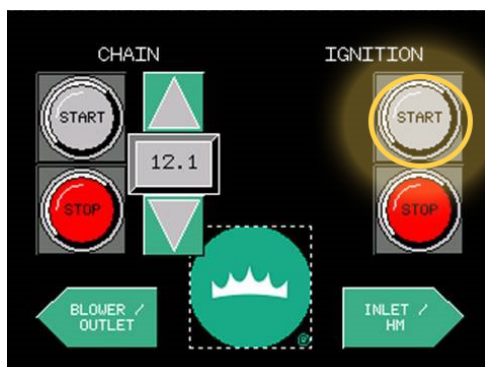

10. Touch the green Blower/Outlet Arrow in bottom left corner

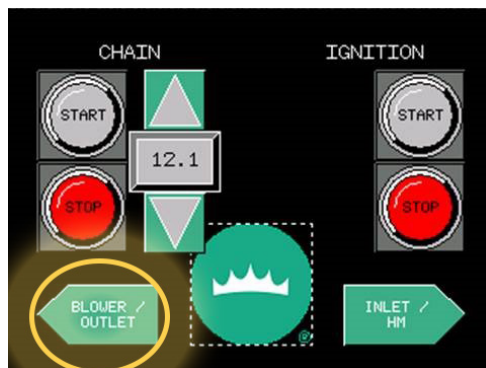

11. Adjust the Blower up to 60 Hz, either by Scrolling or Typing

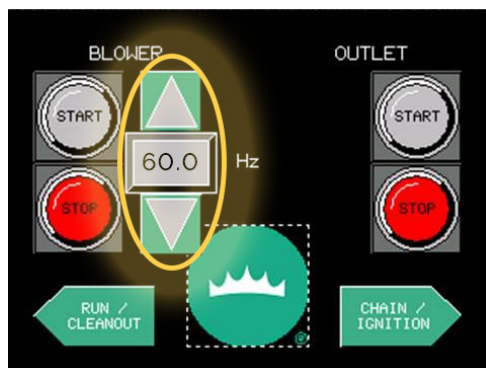

12. Touch the green Crown Circle to go back to the Home Screen

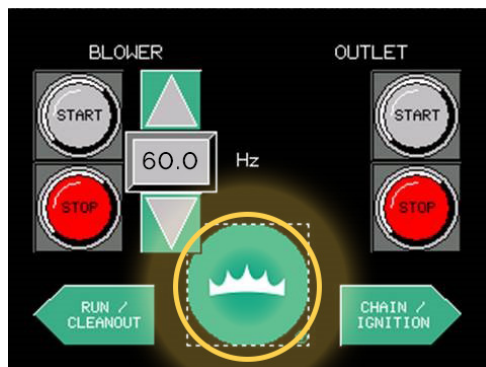

13. Adjust the Product Temperature to your desired setting, either by Scrolling or Typing

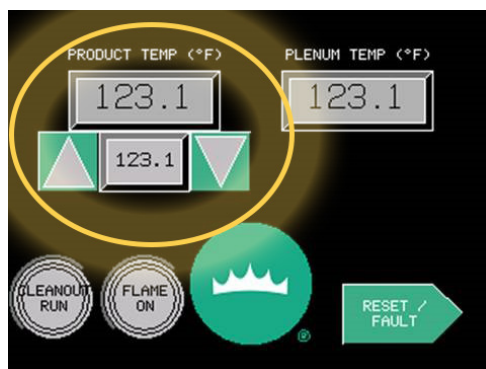

14. When you get up to temperature, scroll back to the Chain/Ignition Screen

15. Adjust your Chain Speed to your desired setting, either by Scrolling or Typing. Touch the Chain Start Button

- You will see the Conveyor Chain and Paddles begin to move in the windows

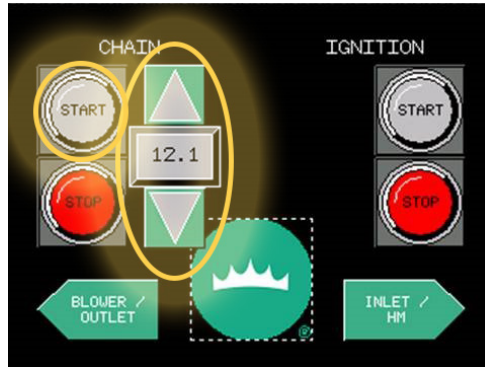

16. Touch green Inlet/H.M. (hour meter) Button.

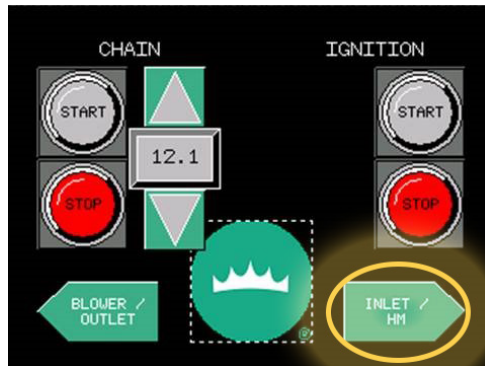

17. Adjust the Inlet Speed to your desired setting, either by Scrolling or Typing

18. Touch the Inlet Start Button

- Now you will see the product running through

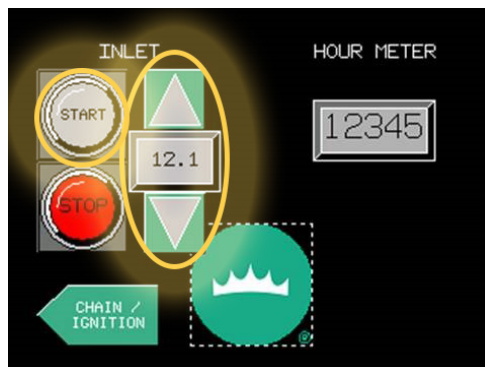

19. Adjust the level of the product to a depth of around 4" on the airbed by adjusting the Inlet, and/or the Chain Speed

SUGGESTED NORMAL OPERATING TEMPERATURES

Normal operating temperatures may vary depending on the product, desired use of product and moisture content of the product. The most important temperature to monitor and control is product temperature. There are three ways to control this.

1. Adjust the Product Temperature. This will raise and lower the temperature inside the plenum.
2. Adjust the chain speed. Raising and lowering the chain speed will affect the length of time the product is being run in the machine.
3. Adjust the rotary inlet. Adjusting the speed at which the product enters the machine affects the depth of the product being run.

Once these settings are set there should only be minimal adjustments made for daily operation. Once the product temperature is at desired level, readings of all settings should be made every hour. Readings to keep track of:

1. Product Temperature
2. Exhaust Temperature
3. Plenum Temperature
4. Chain Speed
5. Rotary Inlet
6. Fan Speed

Keeping track of these parameters will aid in daily operation by allowing you to see the last setting being used. It will also help you keep a database of different product parameters to make switching to different products faster since you will have a baseline already recorded.

A pressure reading of chimney and plenum should also be monitored. A good pressure relationship would be at plus 6.

EXAMPLE: Burner Plenum 7" W.C.
Chimney 1" W.C.
= 6" W.C. differential

MANUAL SHUTDOWN

1. Touch Inlet Stop Button (Screen 6 on HMI)
 - Give time for ALL product to empty from bed section before going to Step 2



2. Touch Ignition Stop Button (Screen 5 on HMI)
3. Touch Chain Stop Button (Screen 5 on HMI)

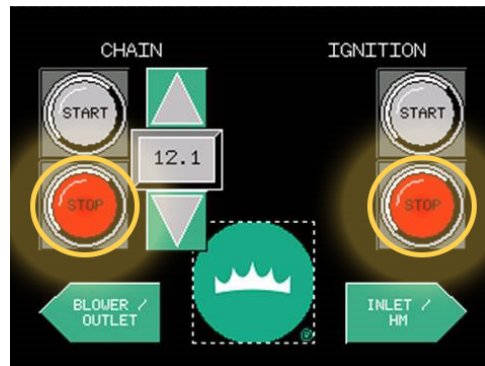

4. Touch Outlet Stop Button (Screen 4 on HMI)
5. Reduce Blower Speed to 30 Hz (Screen 4 on HMI)

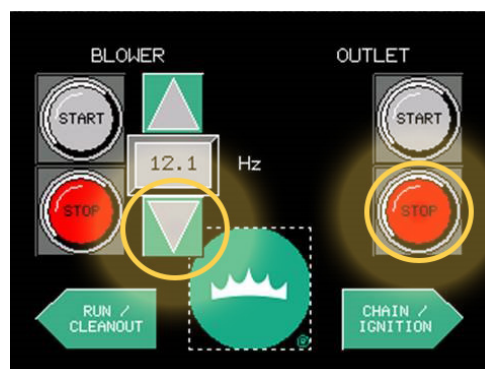

6. When the Plenum Temperature on the Home Screen reads below 100°, Press Blower Stop Button (Screen 4 on HMI)
7. Turn off ALL gas valves
8. Turn Main Power Switch to "Off" position

BURNER SYSTEM SEQUENCE OF OPERATION

1. Both High Limit- Exhaust and High Limit- Plenum contacts must be closed (displays should not show "limit").
2. Hi limit controller should be displayed as SP Low at low temperature of 0°-20° to place unit in low fire position.
3. Start fan.
4. Turn ignition switch to "ON". This provides power to the flame relay.
5. Flame relay "looks" for proof of airflow and correct gas pressure. Then it energizes the purge timer.
6. Purge timer waits 15 seconds, then opens the pilot valve and energizes the ignition transformer to light pilot.
7. Flame relay detects presence of flame and energizes main fuel valve and Run Light. The main valve will then be opened automatically.

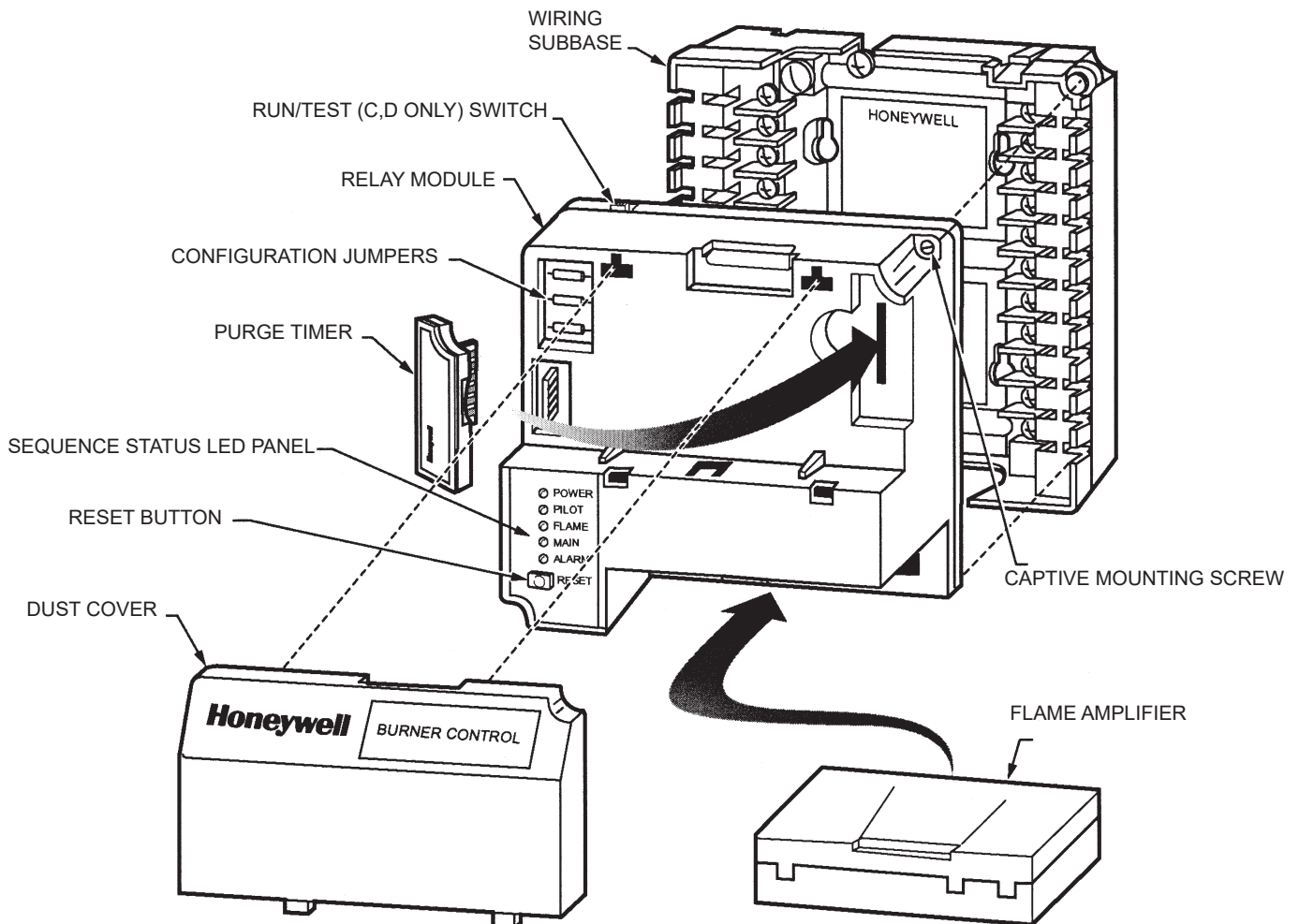

MODEL RM 7895A-1014

SEQUENCE OF OPERATION

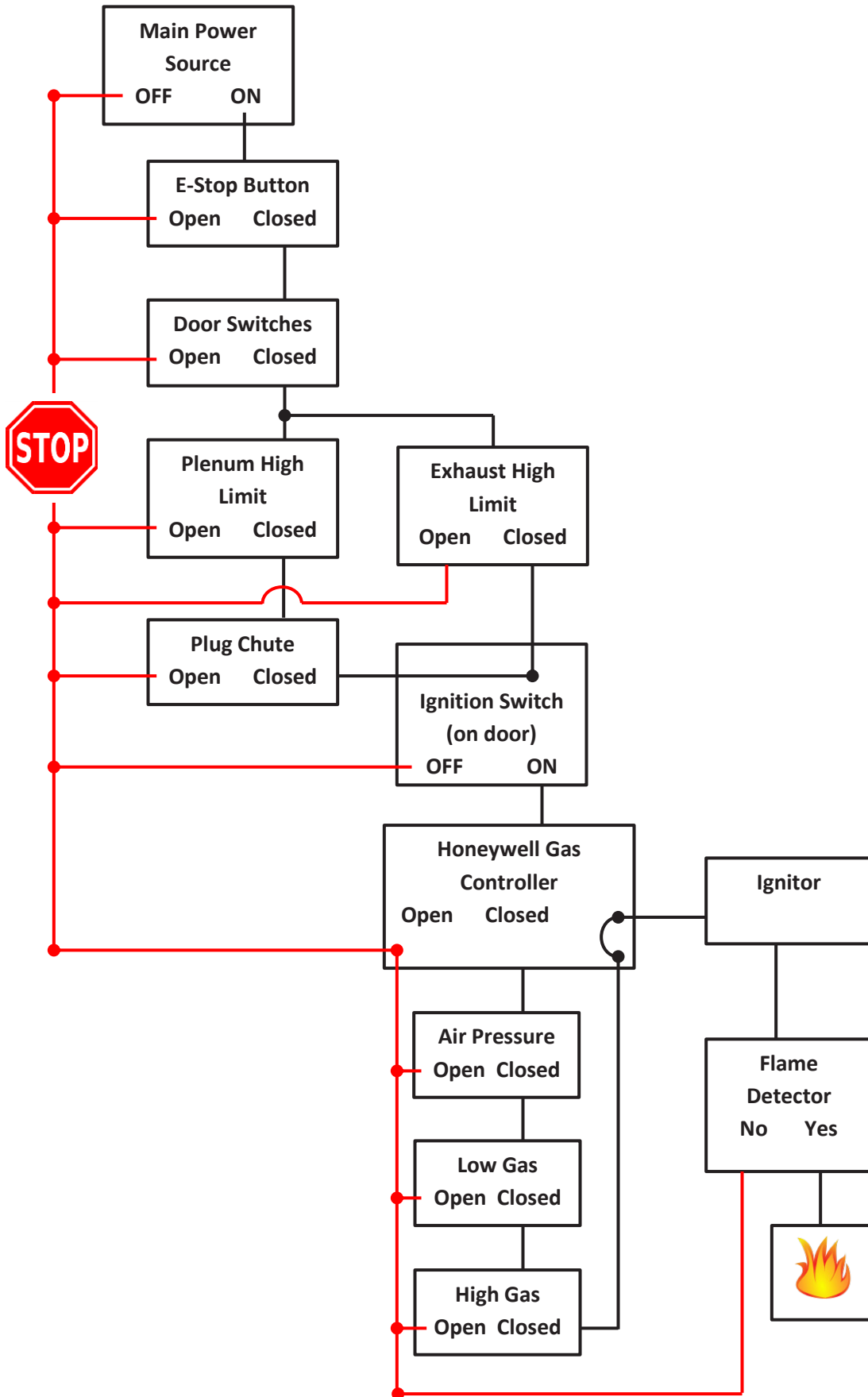

IMPORTANT INFORMATION ABOUT FLAME SENSING SYSTEMS

Flame Rod

This is a rectification type flame system. It senses changes in electric current in the flame rod due to heat from the flame. The relay must sense at least 1.25V DC or shutdown will occur. Typical readings for a system working properly is 2V DC to 3V DC. This system can result in burner shutdown in error:

- a. Excessively wet conditions (short)
- b. Flame rod touching mixing plates (short)
- c. Flame relay over 15' from burner such as control panel mounted remotely. (weak signal)
- d. Foreign material on flame rod - this is usually caused by dirty air coming into fan (results in weak signal).

The components for this system:

Rectification style amplifier

Color code: green

7 1/2" flame rod

Connection: High tension spark cable

CONTROL PANEL

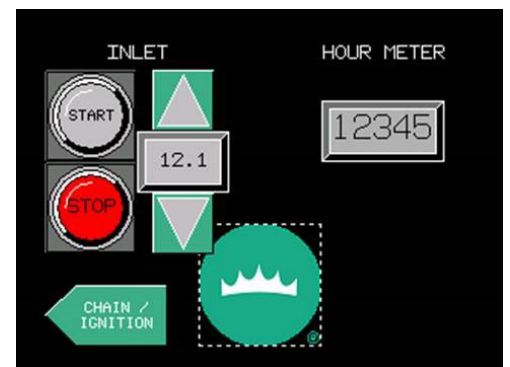
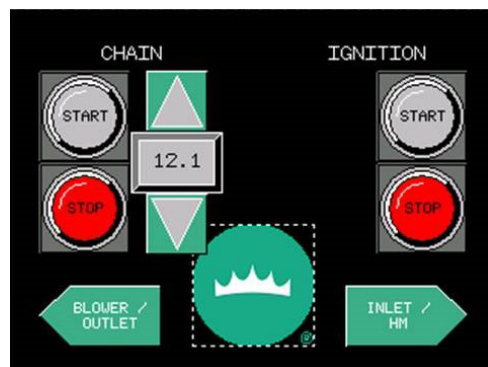
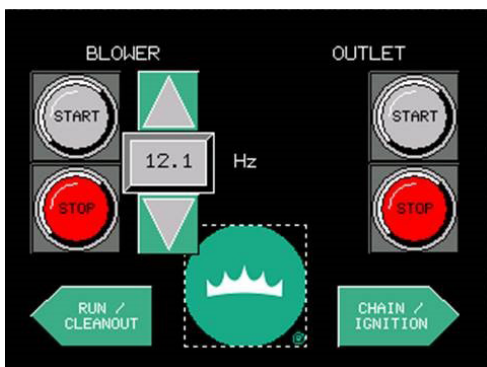
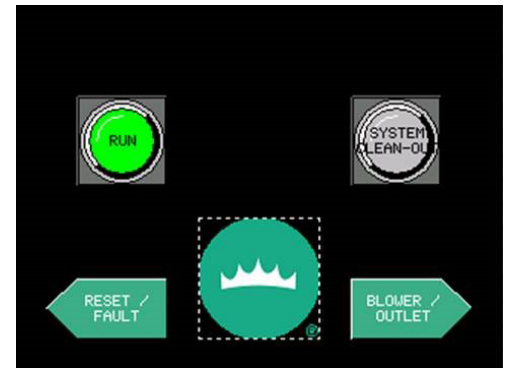
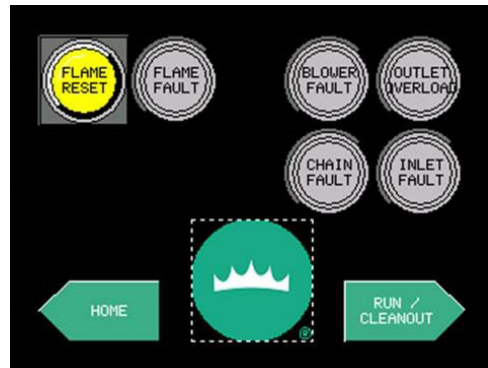
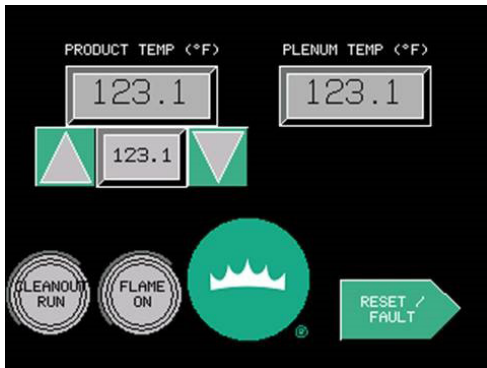

CONTROL PANEL (INSIDE)

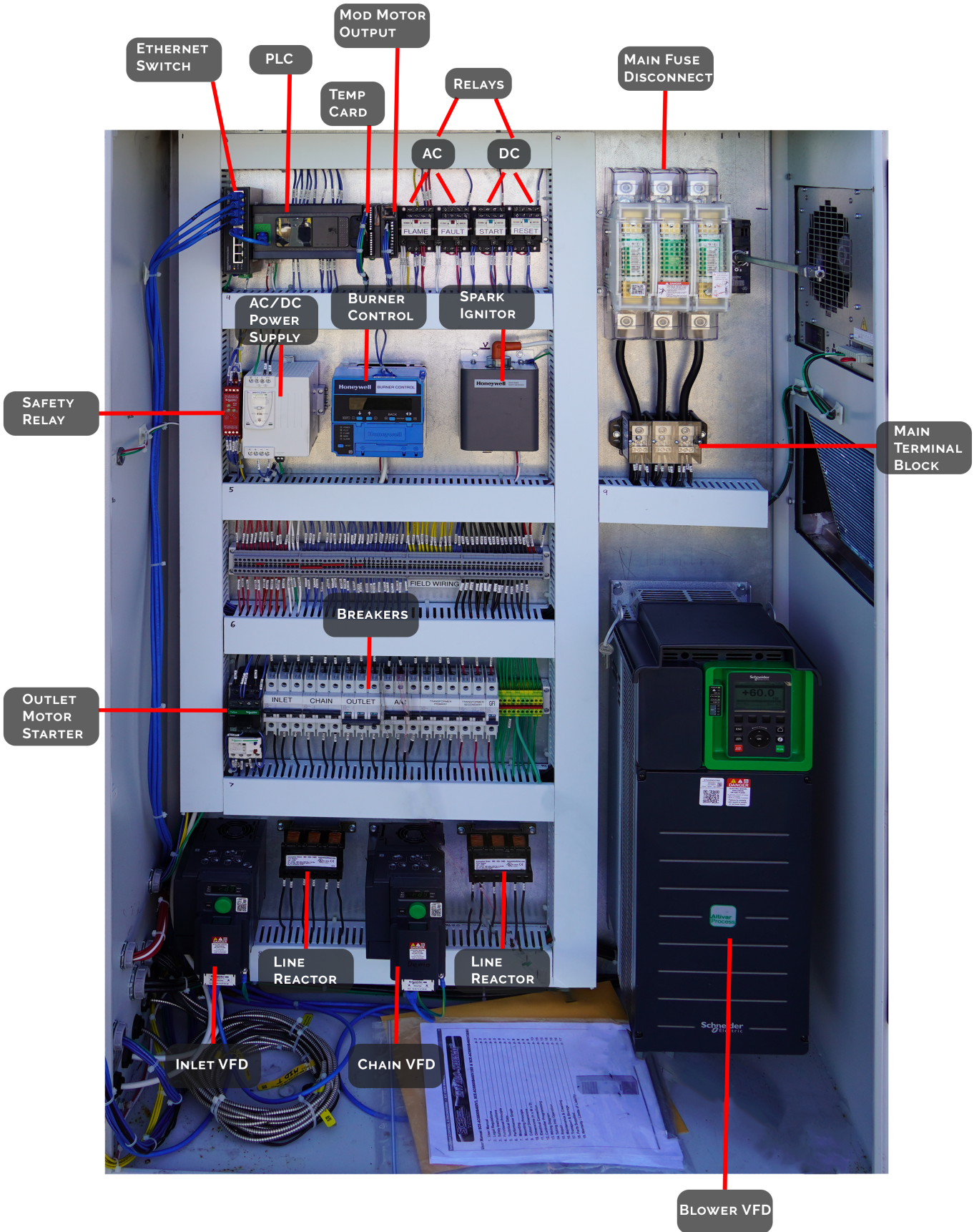

CalorMatic®

DAILY MAINTENANCE

CAUTION: Make inspections when all operations are stopped and CalorMatic® is cool.

1. Inspect for debris in cyclones, airbed, and plenum chamber.
2. Inspect plug chute operation.
3. Inspect mod motor operation.
4. Check door switches. Never bypass switches for any reason.
5. After approximately ten (10) hours of operation, grease all bearings. Retighten all bearing set screws for the head and tail shafts, as well as the bushings on the sprockets and reducer. Check the chain slack in the conveyor and the tension in the drive. This should be repeated every fifty (50) hours of operation.

In event of any faults, error codes, and broken door switches or plug chute contact Sweet product support immediately.

CalorMatic® should never be left unattended due to the potential of fire.

REGULAR MAINTENANCE

Here are some of the things which should be inspected and maintained regularly:

1. Check chain tension. Remove excess chain links if chain cannot be adjusted further.
2. Check fan V-belts for proper tension. Do not overtighten.
3. Check speed reducers regularly for sufficient oil and signs of leakage. Keep breather CLEAN.
4. Check bearings for sufficient lubrication and evidence of overheating.
5. Check all sheaves and drive attaching parts to make sure they are properly secured.
6. Check all hardware and tighten as required.

FAN MAINTENANCE

1. General Safety Notes:
 - A. Rotating parts including shaft and V-belt drives must be properly guarded to prevent personal injury.
 - B. Electrical wiring must be accomplished by a qualified electrician in accordance with all applicable codes.
 - C. Care should be taken:
 - Not to run fan above its safe speed.
 - Not to operate in dangerous environments.
 - Read all instructions carefully.
2. Fans shipped completely assembled have had V-belt drive aligned at the factory. Alignment should be rechecked before operation as a precaution due to handling during shipment. Start the fan. Check for proper rotation. Run fan at full speed. A slight bow should appear on slack side of belt. Disconnect power and adjust belt tension by adjusting motor on its sliding base. All belts must have some slack on one side. If belt squeals at start up, it may be too loose.

TROUBLESHOOTING CHART

SYMPTOM	POSSIBLE CAUSE	PROCEDURE
1. Front panel has no display or partial display	No power to control panel / E-stop pressed	Procedure 1
	Blown fuse X1 or X4 / Door open	Replace
	Blown fuse transformer primaries	Replace
2. Fan will not start	Safety relay 2, controlled by Exhaust High Limit controller is OPEN. Rotary inlet and flame relay will also be de-energized.	Replace
	No power to control panel / E-stop pressed	Procedure 1
	Thermal overload tripped / Door open	Reset
	Blown fuse X1 or X4 or transformer primaries	Replace
3. a. High Limit Plenum b. High Limit Exhaust (flashes limited)	Temperature has exceeded high setting	Procedure 2
	Open thermocouple	Reset
	Temperature below range of instrument (0°F / -18°C)	Procedure 11
4. Flame relay indicated light does not flash when ignition switch is turned on. (fan can be off)	Blown fuse X1 or X4 or transformer primaries	Replace
	Flame relay overload tripped	Reset
	High limit controllers (one or both limited)	Reset
	Plug chute switched tripped	Reset
5. Display shows IN 1FAIL or OFL	Thermocouple open	Procedure 3
6. Pilot will not light	Fan not running	Start fan
	Flame relay overload tripped	Reset
	Safety circuit open - gas, air	Procedure 4
	No earth ground	Procedure 5
	Gas supply off	Turn on
	Pilot gas pressure too high or low	Procedure 6
	Flame relay not sensing flame rod or UV sensor	Procedure 7
	Loose, dirty or wet connections	Procedure 8
	Signal amplifier faulty or defective	Procedure 9
	One or both Hi Limit controllers is limited out	Check cause, then press Reset
No spark at ignitor	Procedure 10	
7. Display shows IN 1 RNG	Instrument out of its operating range limits	Procedure 11
8. Burner goes out intermittently	Flame rod or connections	Procedure 7, 8
	Fluctuating gas pressure	Procedure 12
9. AC drive will not turn in cold weather	Oil in gear case too thick	Procedure 13
10. Operating temperature is erratic & uncontrollable	Gas pressure too high	Procedure 14
11. Operating temperature is too low	Gas pressure is too low	Procedure 15
	Gas volume restricted	Procedure 16
12. Product temperature too low	Plenum temperature is too low	Procedure 17
	Chain speed too fast	Procedure 18
	Product too deep in conveyor	Procedure 19
13. Product temperature too high or burning	Plenum temperature too high	Procedure 20
	Chain speed too slow	Procedure 21
	Product depth too low in conveyor	Procedure 22

TROUBLESHOOTING PROCEDURES

1. Check main disconnect switch or circuit breaker to be sure that it is on. Check line fuses. Also check E-stop and that door is closed.
2. Determine cause of high temperature and correct. Press reset on high limit.
3. Check thermocouple connections on the back of the instrument (red <->, white <+>). If the connections are good, the thermocouple probably has an open short and must be replaced.
4. Check for continuity in air gas switch series terminals # 6 & 7. One lead must be removed from the circuit, the fan must be running and the gas must be on for this test. If the circuit is open, check each switch to determine which one is open.
5. A good earth ground is essential for proper operation of the CalorMatic® controls. Have a qualified electrician ground the machine and control panel according to national and local codes.
6. The CalorMatic® burner utilizes an adjustable pilot orifice instead of separate ones for each fuel type. This is easily adjusted with a hex key wrench. Start by closing the valve completely, then open it two (2) full turns. Try to light pilot in the normal manner. If unsuccessful, adjust orifice in or out until pilot lights. After pilot is established, turn valve in slowly until flame goes out, then open it back up 1/4 turn.
7. Remove flame rod from burner and inspect for dirt, moisture or cracks. Clean and dry the unit and reinstall firmly in burner casting. Also inspect for solid connection with wire and check connection in box.
8. Check all flame rod wire connections for dirt, moisture and corrosion. Also look for nicks or scratches in the wire. Pay close attention to the threaded contact knob on top of the flame rod. It can become loose and cause intermittent contact.
9. Remove signal amplifier by pulling unit straight out of flame relay. Inspect contacts for dirt or corrosion. If anything appears to have been hot or is burnt, contact dealer or factory (lightning likes this part). Reinstall amplifier.
10. Remove spark ignitor from burner and inspect for dirt, moisture or cracks. Also look for premature arcing along electrodes. All sparking should take place at the electrode tip. It may be necessary to spread the ground (bent) lead away from the center slightly. Make certain that the electrodes are at least parallel to each other. Reinstall clean, dry spark ignitor firmly in the burner casting. Be sure wire makes good contact with terminal.
11. Operating range limits for a type "J" low thermocouple are 0-900° F (-18-482° C). If the temperature goes out of this range (usually low), the instrument cannot recognize it. The thermocouple must be brought back into range before the message will go away. Unit may need cold start option installed. Wiring diagram at the back of manual.

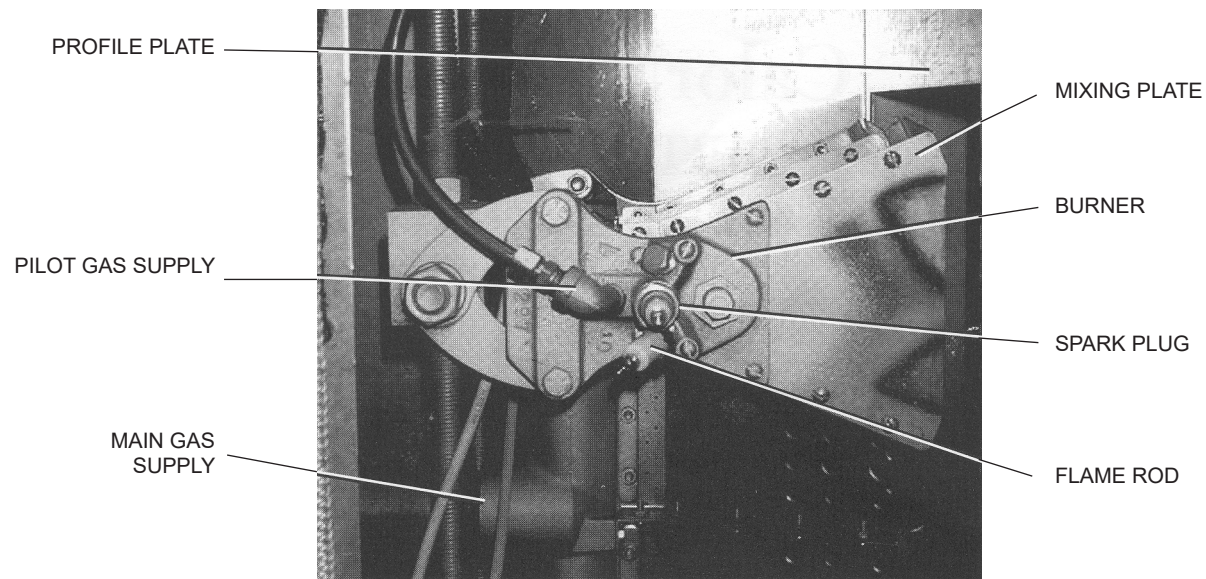

12. Make certain gas supply lines, pressures, and volume are adequate for the burner size. Keep in mind any other gas fired appliances that might be sharing the same device. If the supply is marginal and another unit (i.e. drier or boiler) comes on or calls for gas, the sudden drop in pressure may cause the burner to go out.
13. Reduce gas pressure at main regulator.
14. Increase gas pressure at main regulator.
15. Gas supply piping undersized for volume required or regulator orifice too small. Have qualified gas person verify.
16. Increase plenum temperature (not to exceed 600° F / 315° C)
17. Decrease chain speed gradually (via the HMI on front of control panel using the Chain/Ignition Screen.
18. Decrease speed of rotary feeder (via the VFD on front of control panel using the Rotary Inlet/HM Screen.
19. Decrease plenum temperature.
20. Increase chain speed gradually using the HMI on the Chain/Ignition Screen.
21. Increase speed of rotary feeder using the HMI on the Rotary Inlet/HM Screen.
22. Consult dealer or factory.

CONTROL PARTS

P/N	DESCRIPTION	WEIGHT (LBS.)
0950967	Thermocouple Assembly with 15' lead wire	4.00
0950968	Thermocouple Assembly with 30" lead wire	4.00
0950946	Controller, Hi-Limit HW, DC2500-EE (2017 models and older)	4.00
0950952	Controller, Temperature, HW DC2500-CE (2017 models and older)	4.00
0951066	Pressure Gauge, Magnehelic Dwyer 2020	2.00
0950901	Flame Relay, HW50/60HZ RM7895-1014 (Burner Control)	3.10
0950911	Subbase for flame relay, Q7800A-1005	1.10
0950921	Signal Amplifier, R7847A-1033	0.10
0950931	Purge Timer, H.W. 10 sec. ST7800A-1021	1.00
0950957	Product Temp Thermocouple panel meter, Extech V4054JF1	4.00
0950953	Static Pressure Switch, H.W., C6097A-1004	3.70
0951001	Limit Controller, DC120L:UDC1200 (2018 models, newer)	4.00
0951002	Controller, Temperature, DC2500-CE-0A0R-110 (2018 models and newer)	4.00
0951003	Controller, Temperature, DC2500-CE-0A0R-100 (2018 models and newer)	4.00
	Schneider Modicon M241 PLC Unit	2.0
	Schneider TM3T14 Analog Input	1.0
	Schneider TM3AQ4 Analog Output	1.0
	Ethernet Switch	1.0

IGNITION PARTS

P/N	DESCRIPTION	WEIGHT (LBS.)
0951030	Spark Igniter	0.12
0951035	Miniature Flame Rod	0.14
0950905	Ignition Transformer	3.10
0001809	Ignition Cable 35,000 V high temperature, priced per ft.	0.02
0951031	Spark Plug Terminal	0.10
0951032	Spark Plug Boot	0.01

GAS LINE PARTS

P/N	DESCRIPTION	WEIGHT (LBS.)
0951067	Pressure Gauge, 30"/2.5"D/1/4NPT, 0-60, H2O	1.50
0950935	Modulating Motor Honeywell M7284A-1004	8.80
0951052	High Gas Pressure Switch, HW, C6097A-1079	3.70
0950947	Low Gas Pressure Switch, C6097A-1053	3.70

MISCELLANEOUS PARTS

P/N	DESCRIPTION	WEIGHT (LBS.)
0452598	Caulking, High Temperature red silicone sealent	0.50
0950044	Pane, Windowside, 3/8" Tempered	6.25

CalorMatic® Factory Inspection Checklist

Model: _____ Serial # _____

End User: _____

- _____ All parts are installed per order specifications.
- _____ Conveyor chain is properly tensioned.
- _____ Head / Tail shafts are properly aligned.
- _____ Head / Tail bearing set-screws are tight.
- _____ Review all electrical connections.
- _____ Chain travels freely in correct direction.
- _____ Rotary Outlet drive assembly reviewed for proper sprocket alignment, chain tension, and tightness of set screws.
- _____ Rotary units turn freely with correct rotation.
- _____ DC drive boards adjusted for minimum and maximum output.
- _____ Fan drive assembly reviewed for proper sheave alignment, V-belt tension, and tightness of set screws.
- _____ Fan motor contacts tested for activation.
- _____ Fan turns correct rotation.
- _____ Fan motor RPMs checked: _____RPM
- _____ Fan RPMs checked: _____RPM
- _____ Fan motor amperes checked: _____Amps
(If available electric service permits.)
- _____ Static pressure checked. Plenum: _____Inches Chimney: _____Inches
- _____ Doors and windows are properly installed and sealed.
- _____ Correct programming of Temperature and Hi-Limit controllers confirmed.
- _____ Gas train checked for leaks.

- _____ Start-Up performed.
- _____ Spark confirmed.
- _____ Pilot flame confirmed and adjusted.
- _____ Main valve activated.
- _____ Modulating motor activated and adjusted.
- _____ Continuity of flame rod confirmed.
- _____ Air / Gas pressure switches checked and adjusted.
- _____ Temperature display functions properly.
- _____ Hour meter functions properly.
- _____ Plug chute switch functions properly.
- _____ Hi-Limit controllers function properly.
- _____ Wiring is re-set for customer's electric service.
- _____ Unit cleaned and touched up with paint if necessary.
- _____ Fan motor is greased.
- _____ Feet for weather covers installed on cyclones if applicable.
- _____ Cyclone and cyclone transition attachment hardware is included.
- _____ Safety decals / notices installed.
- _____ CalorMatic® Operator Manual and manuals for components packed in control panel.

Technicians Signatures:

 Name Clock # Date

 Name Clock # Date



Manufacturing Company
 2000 E Leffel Lane - Springfield Ohio 45505 USA
 Phone: (937) 325-1511 E-Mail: sales@sweetmfg.com

CalorMatic® Training Sheet

Model: _____ Serial # _____

End User: _____

Date/s _____ Site _____

Subject of Training: Start Up and Shut Down of CalorMatic® and Daily Maintenance/Inspection of CalorMatic®. Review of the manual and troubleshooting.

Attendance (Names)

Signature

_____	_____
_____	_____
_____	_____
_____	_____
_____	_____
_____	_____
_____	_____
_____	_____
_____	_____
_____	_____
_____	_____

End-User Supervisor Signature _____

Sweet Trainer _____

REMARKS: _____

(Sweet keeps original and copy goes to customer)



2000 E. Leffel Lane • Springfield, Ohio 45505
Phone: (937) 325-1511 • Email: sales@sweetmfg.com

www.sweetmfg.com